

RADIO BROADCAST

Vol. 5, No. 2



June, 1924

Can We Save Millions by Altering the Telegraphic Code?

From a Close Study of the Plan Proposed by Major-General George O. Squier It Would Seem Possible. This plan deserves Serious Consideration

By ARTHUR H. LYNCH

SOMEONE has been sleeping. In fact so many of us have been sleeping that we've simply let a problem involving a saving of millions slip right by for more than seventy years* without troubling for a solution. Perhaps our noses have been so close to the picture as to distort our perspective. Major-General George O. Squier who told this story to me at the Metropolitan Club in Washington, D. C., a few weeks ago said: "The neglect on the part of the radio telegraph industry to alter its only product is a problem in psychology of sufficient magnitude to warrant the study of a James."

"Our automobile factories, for instance," continued the General, "are never satisfied with the product they turn out. Even though they spend veritable fortunes for machinery to make a certain type of car, whether it be a truck or a luxurious sedan, they go right on developing new models. And they find it profitable.

"More efficient cars, more efficient production methods, more rapid turnover and a greater volume of business usually result in a lower price and better service to the consumer and the demand continues to grow each year.

"Can you imagine any automobile corporation attempting to sell wheelbarrows produced in factories capable of turning out the best-grade pleasure car in the world?" The General's eyes sparkled and the color rose in his cheeks as he continued: "That's exactly what we're trying to do in radio telegraphy—and they're flat-wheeled barrows at that.

"WE ARE ASLEEP IN RADIO"

WHY, just imagine how ridiculous it would be for a factory representative of any large company attempting to secure orders for his product from samples made in 1851 or thereabouts! It's preposterous.

"Now, let me briefly outline for you what I maintain is one of the greatest pieces of neglect in the entire communications art. Then, having told you of our short-sightedness, let me tell you what I think about solving the problem. Understand me, I do not maintain that my method of solving the problem is the best method, nor that it is impossible to improve upon it. All I want to do is to demonstrate the need for a revision of our radio, telegraph and cable traffic which will cause a great financial saving annually. Then I want to tell you how I believe it can be done. If my system can be

*The present radio alphabet was adopted by the Vienna Convention for European languages in Oct. 1851.

improved upon, so much the better. All I claim for it is that it is a step in the right direction.

"Radio's function, or to be more exact, one of its present functions, is to transmit intelligence from point to point. In the case of ships at sea and aircraft it is the only method. When we send a telegram or a cablegram or a radiogram, we pay to have a small piece of paper, bearing a few characters, delivered to a person or persons some distance from us. The more messages we wish sent, the greater the number of little papers the company delivering them must be able to take care of satisfactorily. In many instances the lines between us and the person on the other end are heavily laden with messages sent by other folks and our messages suffer a delay.

"Something must be done to offset the delay. It is sometimes necessary, because of the great volume of traffic to have a great many similar lines between two points to carry the heavy burden of traffic. Engineers, ever since electric signaling was discovered have studied the action of the machines used in transmitting and receiving this intelligence. They have made astounding improvements and have increased the speed of transmission many, many times. Why it was but last night that both you and I witnessed a transmission of a dot sent from the lecture room of the Cosmos Club to Warsaw and back again to Washington before we could say Jack Robinson.

"If we had suggested any such thing a few years ago people would have shaken their heads and have had grave doubts of our mental stability. But it was done before our very eyes.

"Although my plan is not at all confined to radio but may be employed on the cables and telegraph and even the telephone lines, we will do well, for the purpose of explanation to stick to radio and the necessary changes for all forms of wire application will suggest themselves to most of your readers.

"You know as well as I do that radio transmission, especially over long distances, such as between America and Europe is subject to certain atmospheric disturbances during the summer. Although engineers have made great strides in overcoming this interference there are many periods when it is necessary for the transoceanic traffic to be handled at very low speed and when it is necessary to have each word repeated two or three times.

That means a severe crowding of the ether lane used by any two stations being used for intercommunication and the few available wavelengths preclude the possibility of doubling up the number of stations to offset this difficulty.

"If we consider that for a definite period of unfavorable atmospheric conditions it were possible for us to double the speed of transmission during the favorable hours of each day, we would double the revenue of our system for that period. Further than that—you know that most of the messages sent from this country to Europe are important. Many of them have to do with ships, shipping, foreign exchange and so on. With each day, the importance of our communication with Europe becomes even greater. Offsetting by even a few moments in the delivery of a message sent by one of the large banks, like the Irving National or National City Bank to a bank in Germany or England may result in preventing a loss of thousands of dollars to American investors. Commerce to-day is on what manufacturers are pleased to term a production basis. Speed in communication is everything.

"Manufacturers in most lines spend thousands yearly, attempting to lower costs of production by saving a little time here and a little material there. Efficiency seems to be our war cry and it is just here that radio suffers by comparison with other industries.

PRODUCING CAVE-MAN VEHICLES IN LIMOUSINE FACTORIES

"WE'RE selling a seventy-year old model and turning it out in modern factories. We have million dollar factories on occasion covering many square miles for the sole purpose of sending dots and dashes. We have been in short, perfectly content to take things as we find them and make the best of it."

Then the General took a long pull on his cigar, looked at the ceiling and exhaled the smoke slowly and thoughtfully. He smiled, sensing my unspoken question.

"Oh, no!" he said, "I am not discounting any of the wonderful work the engineers have accomplished, either in the design of transmitters or receivers. I am merely saying that they have overlooked the little pieces of paper that carry the thoughts of one individual to another.

"Their transmitters and receivers are wonderful. But the product of the factories must



MAJOR-GENERAL GEORGE O. SQUIER (RETIRED)

Who, since his retirement on January 1st as Chief Signal Officer of the army after more than forty years of continuous service, has been indulging in long deferred plans to carry out experimental work in electrical communication engineering

equal lengths of time and have equal importance, whether they were dots, dashes or spaces. The signals were distinguished by varying the intensity of the individual sending elements, i.e., a dot, dash or space occupied equal time lengths, but were of different intensities. The variation in intensity for signalling was effected at the transmitter at the zero phase of the resultant current flowing into the cable, so that, theoretically, at the moment of any operation upon the current there was no current to operate upon.

"A point of fundamental importance in this method is that no two adjacent signals are of the same sign, since each semicycle is utilized to effect signaling, giving a dot, dash or space. Other things being equal, the variation in intensities for each of the three elemental signals are reduced to a minimum on the theory that the minimum possible change of the fundamental wave should be made. The reason for this is that an alternating current in the steady state, which amounts to a series of the present cable letters 'a' or 'n' strung together without space, can attain a speed in any form of telegraphy many times greater than any practical system. A sinusoidal wave is transmitted through any form of electrical circuit without distortion of any kind, and, in

fact, is the only type of wave that is so transmitted.

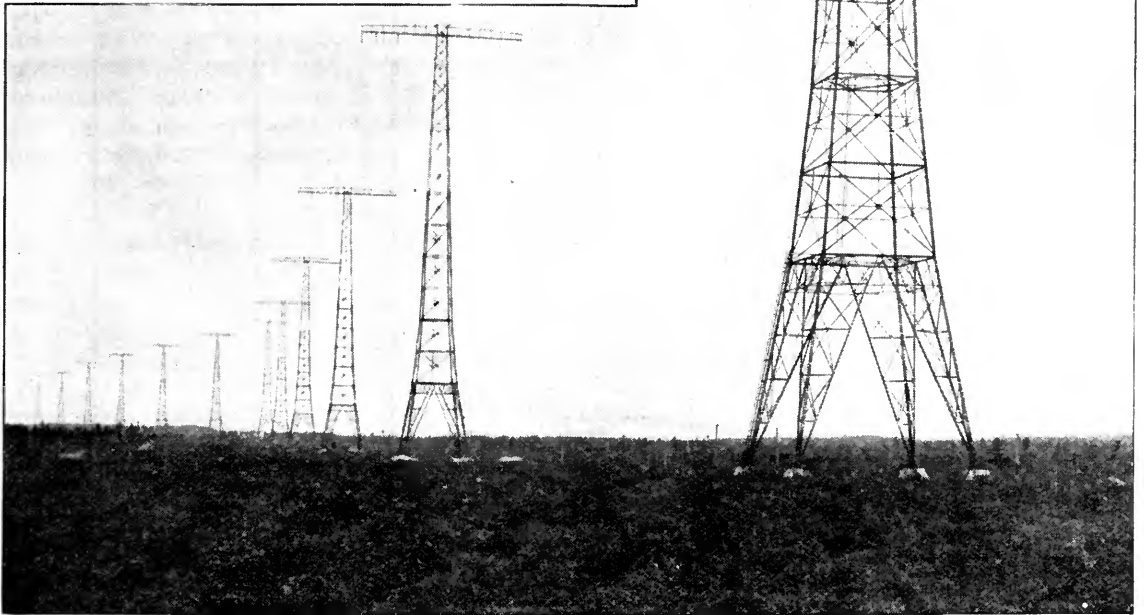
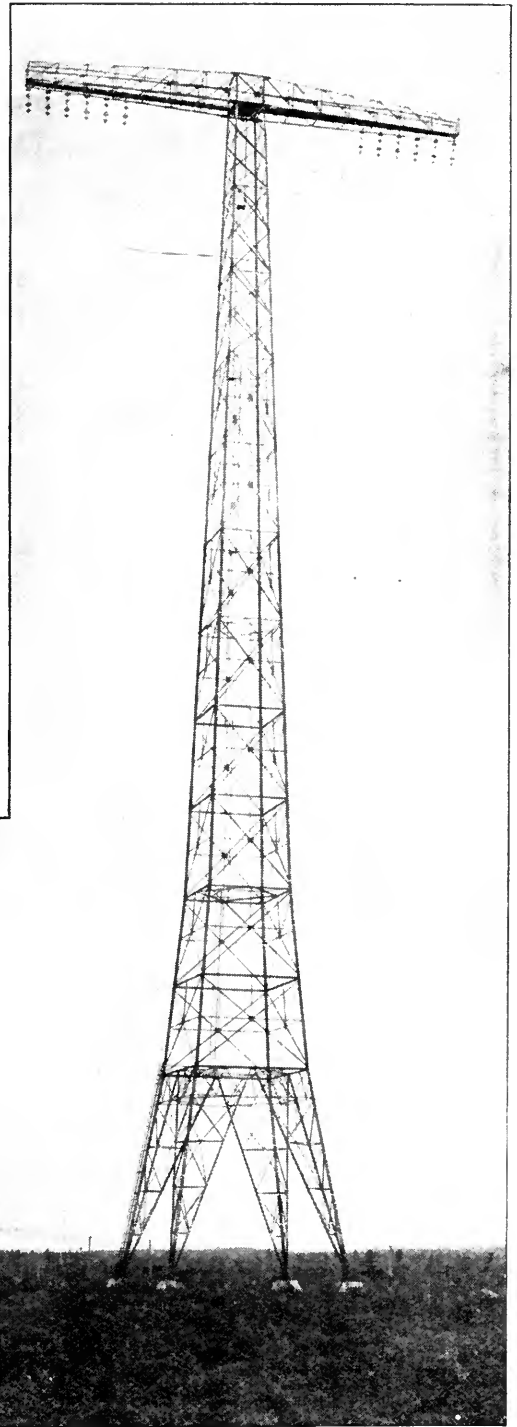

ARE TRANSOCEANIC RADIO STATIONS WASTING MONEY WITH A NEEDLESSLY SLOW CODE?

The photograph shows the towers of the Radio Corporation of America station at Rocky Point, Long Island, which communicates with England, France, Norway, Poland, Germany, and Italy

TABLE II
COMPARATIVE SIGNALING SPEEDS OF INTERNATIONAL MORSE AND
SQUIER ALPHABETS

(Weighted according to the frequency of letters in telegraphic English as given by Hitt, based on an actual count of 10,000 letters.)

The following bases for comparison as regards spacing and length of signals are employed: (See page 22, Universal Electrical Communications Union, Washington, 1920).

Element	International Morse	Squier Alphabet
Dot	1 unit	1 unit
Dash	3 units	1 unit
Space between parts of same character	1 unit	0 unit
Space between letters	3 units	1 unit
Space between words	5 units	2 units

Letter	Signals	Frequency in 10,000	Units in Int. Morse	Units in Squier Alph.	Weighted Int. Morse	Weighted Squier Alph.
A	--	813	8	3	6504	2439
B	----	149	12	5	1788	745
C	----	306	14	5	4284	1530
D	---	417	10	4	4170	1668
E	.	1319	4	2	5276	2638
F	----	205	12	5	2460	1025
G	---	201	12	4	2412	804
H	----	386	10	5	3860	1930
I	..	711	6	3	4266	2133
J	-----	42	16	5	672	210
K	---	88	12	4	1056	352
L	----	392	12	5	4704	1960
M	--	273	10	3	2730	819
N	-	718	8	3	5744	2154
O	----	844	14	4	11816	3376
P	----	243	14	5	3402	1215
Q	-----	38	16	5	608	190
R	---	677	10	4	6770	2708
S	...	656	8	4	5248	2624
T	-	634	6	2	3804	1268
U	---	321	10	4	3210	1284
V	----	136	12	5	1632	680
W	---	166	12	4	1992	664
X	----	51	14	5	714	255
Y	-----	208	16	5	3328	1040
Z	-----	6	14	5	84	30
TOTALS		10000	292	108	92534	35741
Add for spaces between words, 10,000 letters = 2,000 words					3998	1999
GRAND TOTALS					96532	37740
Average number of units per word					48.266	18.870

Ratio = 48.266 : 18.870 = 2.56 Squier Alphabet is 156% faster than International Morse

Both tables were prepared under the direction of General Squier by Captain Friedman, Chief of the Code Section of the Signal Corps. It is the result of many months of research

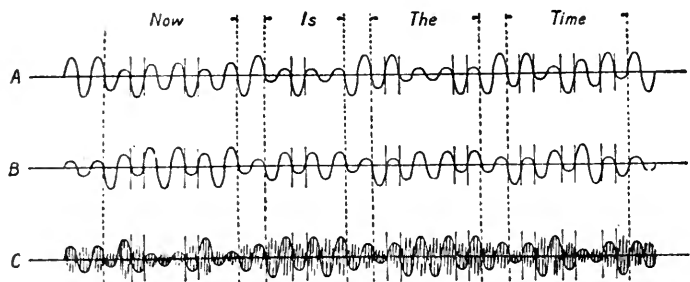

(A) Dot—smallest amplitude. Dash—medium amplitude. Space—largest amplitude.
 (B) Space—smallest amplitude. Dot—medium amplitude. Dash—largest amplitude.
 (C) Dash—smallest amplitude. Space—medium amplitude. Dot—largest amplitude.
 There are three other possible permutations of amplitudes not shown here. Ratio of amplitudes of signalling units arbitrarily assumed as 1: 2: 3.

FIG. 1

HOW THE SQUIER SYSTEM WOULD WORK

A STILL more important point to be considered is the transmission of the largest volume of telegraphic business with a minimum number of signals, and from this angle the new form of alphabet has most striking advantages.

“Fig. 1 illustrates graphically this method of modulating a single-frequency wave, and shows the words ‘Now is the time’ as they would be transmitted by this method, in which we arbitrarily assign the largest amplitude for a dash, the next size amplitude for a dot, and the smallest for the spaces between.

It is well known that the sudden breaking or introduction of high impedances in an alternating current circuit produces transient phenomena which results in a whole group of harmonics being transmitted. Add to this the practical condition of performing this operation upon a current ranging all the way from zero to hundreds of amperes, and it is easily seen that the ether of space is bombarded with a mass of frequencies never twice alike even in the same letter. It is little wonder, therefore, that no method has yet been devised to prevent such a disturbance from interfering radically with the reception of radio signals. Entirely apart, therefore, from a gain of more than 150 per cent. in the transmission speed, from an interference standpoint the present method is about as bad as it could well be.

“At present the radio engineer has utilized and made his own all of the audio-frequency range and at least several octaves of the radio-frequency range, and has devised apparatus for the amplification and rectification of both of these ranges, audio and radio. This plan

proposes to enter the unused infra-audio range, which would not only add a most useful band of frequencies to those now used, but would give a band below the range of the human ear. If this band were employed for telegraph, an additional advantage would be that it could not interfere with any radio receiving. This method of eliminating interference would be most effective.

“Finally, it is seen that by the method proposed here it is possible to modulate a single frequency

by a number of modulating frequencies, and thus multiply the capacity of each radio frequency channel.

“In 1921 the writer attended at Paris an international technical conference on outstanding radio problems, and for two months special delegates of the five great powers gave consideration to technical points connected with international radio telephony and telegraphy. Such matters as interference, logarithmic decrements, disposition and allocation of wavelengths, radiation, etc., were considered. It is now proposed that the general subject of a suitable method for transmitting telegraphic signals either for radio, land lines or submarine cables be considered at the next international technical conference, with a view, if possible, of unifying all branches of telegraphy using the same system of modulation for the signals.”

From all this we may rest assured that the next international conference which undertakes radio problems will devote much of its energy to a revision of the telegraphic code. It is quite possible that some effort in this direction will be made at the Pan American Congress to be held in Mexico City within the next few months. It will be well to consider General Squier’s work very thoroughly.

The radio amateur, whose transmitter and efficient receiver make it possible for him to chat with his neighbor over a distance of several thousand miles is beginning to feel the need for a universal language. He may well direct his effort to constructive work in revising his method of operation to conform with this more efficient vehicle and last but not least our great radio companies carrying on, as they do, about a quarter of our communication with Europe cannot afford to overlook the opportunity which General Squier points out as being capable of increasing their output by some 150 per cent.

How to Build a Knock-Out Four-Tube Set

Incorporating with the Knock-Out One-Tube Reflex Receiver a Quiet, Inexpensive and Dependable Resistance-Coupled Amplifier

By ZEH BOUCK

THE outstanding characteristic of crystal rectified (detected) receivers, such as the single tube reflex set described with variations in recent issues of RADIO BROADCAST, is the good quality and clarity of the output. The remarkably clear tone reproduction of the crystal detector is due to the rectifying properties of the mineral, which delivers an audio-frequency current varying directly with the potential of the applied voltage. This is not the case in detection by the three-element vacuum tube. It is doubtful if this naturalness of tone will ever be improved upon, and the enthusiast who is satisfied with the volume of a single tube reflex, need search no further for perfection in detecting fidelity.

However, it is difficult to preserve this clarity when amplifying in the conventional manner. This close approach to perfection cannot be carried through two ordinary stages of transformer-coupled audio intensification. Though the output is still superior to that delivered by most amplified regenerative receivers, it has lost that subtle quality that stamped it as perfect. This is particularly noticeable in amplifying the single tube reflex receiver, due to the capacitive feedback between the external amplifier and the tuning unit. The measures taken to stabilize the whole, such as condensers connected to the amplifying grids and grounded, lessen amplification and, in some particularly obdurate cases, tend to increase the distortion prevalent, if not inherent, in transformer-coupled amplifiers.

The push-pull

ably represents the nearest approach to perfection yet achieved in transformer-coupled audio amplifiers.

THE RESISTANCE-COUPLED AMPLIFIER

WHILE it is possible, in the laboratory, by means of certain balancing and corrective measures, such as the Campbell filter, to obtain perfect transformer-coupled amplification, the writer has never heard a two-stage amplifier with an output quality equal to that of a three-stage resistance-coupled audio intensifier. It is significant, that in many broadcasting stations, where perfect amplification is essential in the speech amplifiers, the simple resistance-coupled method is often used in preference to complicated transformer circuits, which their financial and laboratory resources make available.

The reader will better appreciate the possibilities of the apparatus we are going to describe, if, first, we make clear the theoretical functioning of such amplifiers, one of the most interesting of radio phenomena, quite easily comprehended.

The resistance-coupled amplifier is *not* new. On the contrary, the chances are that it is the oldest form of amplifier, the system being probably the direct and logical outcome of early experiments to determine the voltage amplification of the three element vacuum tube.

However, until the very recent advent of telephonic radio broadcasting during those twelve years when telegraphy was ninety-five per cent. of wireless, distortionless amplification was actually

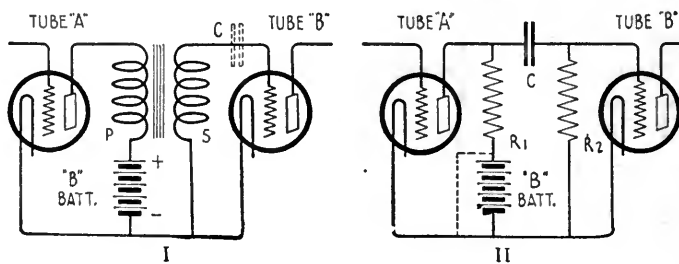

FIG. 1

Comparing the theories of resistance- and transformer-coupled audio amplifiers. There is not a great deal of difference

undesirable, and so, without the recommendation of its predominant and only advantage, the resistance-coupled audio amplifier was practically forgotten. The transformer-coupled type gave greater amplification per stage, particularly when the windings were designed to pass the narrow band of audio frequencies to which telegraphic tones were confined. It is only now, after three years of redesigning and rewinding of the old code amplifying transformers, that the resistance-coupled amplifier is being salvaged from the radio junk pile.

Fig. 1 is divided into two parts, showing amplifying tubes coupled in two systems, A and B, respectively transformer-coupling, which we all know, and resistance coupling which, I hope, the reader will soon know and appreciate.

Amplifier A functions in a manner very easily understood. The plate current, set up by the potential of the B battery, flows through the primary, P, of the audio amplifying transformer. This current is made to vary by signal impulses applied to the grid of tube A. When this current fluctuates, a potential, or voltage, varying with the strength of the plate current of tube A, is induced in the secondary winding. This secondary potential is applied to the grid of tube B—that is, the voltage is impressed across the grid and filament. Condenser C, drawn in with dotted lines, is suggested in

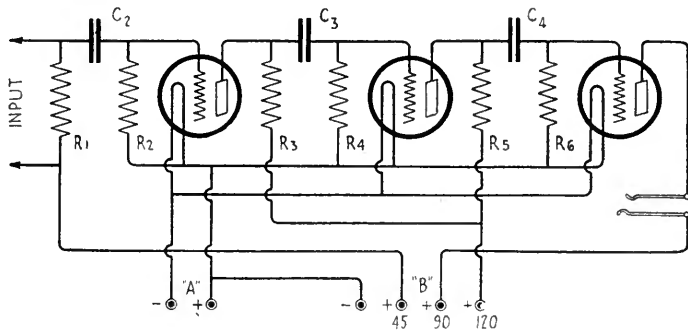

FIG. 2

The fundamental circuit of a three stage resistance-coupled amplifier

order to make the action of circuit B clearer a little later on. The amplifier would function quite nicely with this condenser (about .0025 mfd. or greater) in the circuit, but, as there is no necessity for it, we do not include it in the conventional transformer amplifier.

We may therefore sum up amplification by stating that its requirements are a potential,* varying with the plate current of the preceding tube (A), which can be applied to the grid circuit of the succeeding tube (B). If we comply with these conditions, we have amplification.

Bearing this in mind, we proceed to circuit B, which depicts two similar bulbs coupled by a resistance, R1. Condenser C is placed in this circuit to isolate the grid from the high

*This potential must, of course, exceed that applied to the grid of the preceding tube. The amplifying ability of the tube automatically takes care of this.

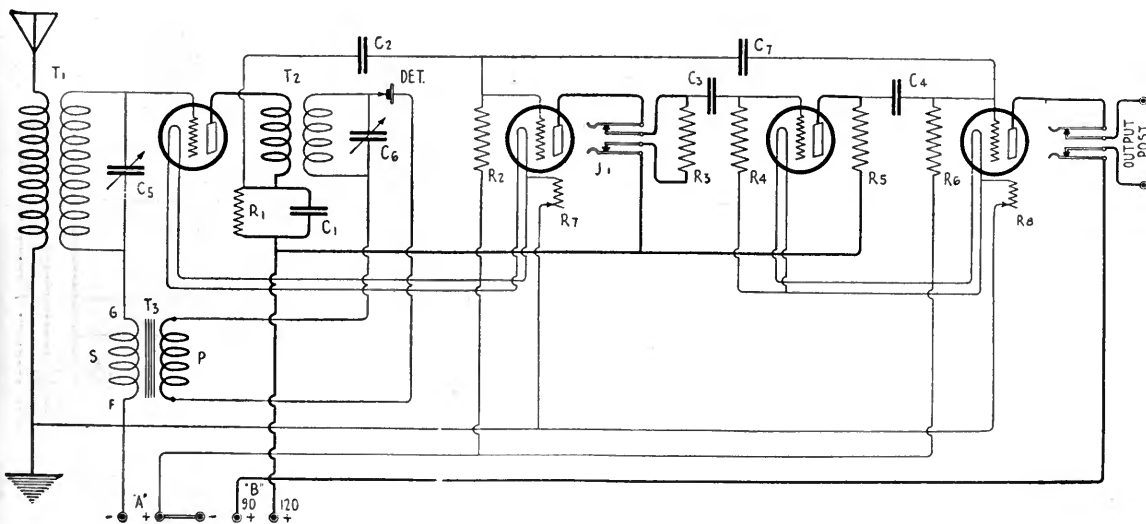

FIG. 3

The complete circuit of the receiver described in this article



FIG. 4

Front view of the completed receiver. Only two tuning controls as usual

plate potential. This circuit is quite similar to circuit A, though the unpracticed eye may not at first recognize the numerous relations. We have our plate circuit in tube A, from the plate, through the resistance R_1 (instead of the primary of the amplifying transformer), the plate battery, and from there, down to the filament. We also have our grid circuit—the grid of tube B, through condenser C and down resistance R_1 . Resistance R_1 is therefore common to both the plate circuit of tube A and the grid circuit of tube B, acting more or less as a double substitute for primary and secondary of the audio transformer. Hence, if we can show that there is a varying potential across this resistance, which changes with the grid variation of tube A, we shall have established the fact that circuit B is an amplifying system, in which the functioning automatically becomes quite clear.

Ohm's law states that the current is always equal to the voltage divided by the resistance — I (current) equals E (voltage) over R (resistance), i. e., $I = \frac{E}{R}$. Transposing, this very fundamental law also postulates that the vol-

tage across any resistance is equal to the current times the resistance, in other words, $E = I \times R$.

E , in the case we are proving, will be the plate voltage; I the plate current; and R the coupling resistance, R_1 . The plate current varies with the grid potential of tube A. Thus, as the potential

across R_1 is always equal to the momentary value of the current times its resistance in ohms, this potential will vary directly with the grid impulses. That is, this circuit amplifies.

THE FUNDAMENTAL CIRCUIT

FIG. 2 shows the fundamental circuit of a three stage resistance-coupled audio amplifier. This amplifier is about equal to two stages of the best transformer-coupled amplification, as far as volume is concerned, and is noticeably superior to the best in quality. Its extraordinary purity of tone will be especially noticed in the reproduction of a woman's singing voice. Barring any distortion at the transmitting end, the notes will come through liquid and pleasing, a marked contrast to some of the strident reproductions of the vocal attempts of a broadcasting coloratura soprano.

The resistance of the coupling resistance, R_1 , R_3 , and R_5 varies in the opinions of individual experts, and also from the theoretically correct value (which is infinitely high). However, experience has indicated that 100,000 ohms is the best value when using the amplifying

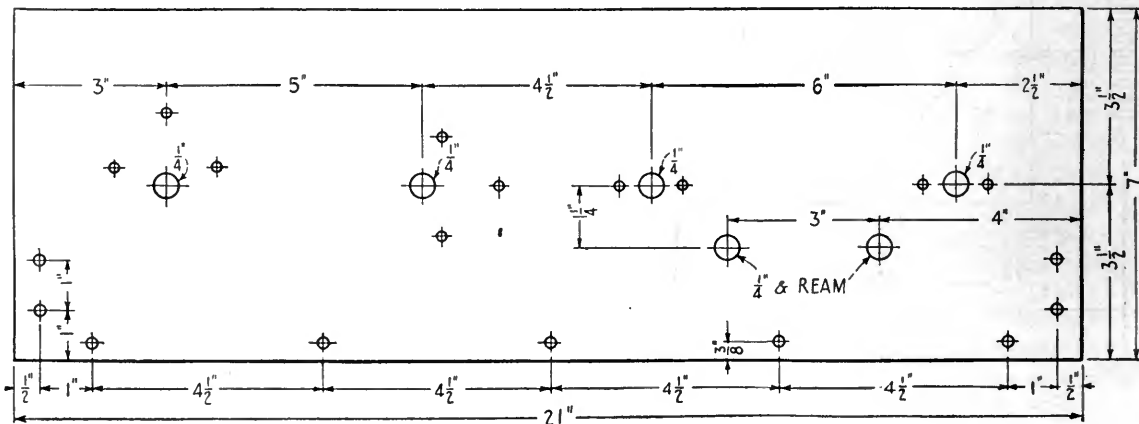

FIG. 5

The panel layout for the Four-Tube Knock-Out

tubes now available to the broadcast receiving public.

It will be noticed that there are three separate B battery taps—one for detector (about forty-five volts, compensating for the extra plate resistance, R_1), the second (ninety volts) to the plate of the last tube, which circuit contains only the comparatively low resistance of the loud-speaker winding, and the third and highest voltage tap to the plates of the amplifying tubes through the high resistance coupling units. Using the UV-201-A tubes, this voltage arrangement will result in approximately the same total current consumption as a two step transformer-coupled amplifier, operating without a negative grid bias, and with ninety volts on the plate. Each amplifying tube with a plate coupling-resistance, will draw about one one-thousandth of an ampere.

Considering the current consumption, as well as the extra tube and B battery, but balancing with the economy of coupling-resistances as compared with the cost of good amplifying transformers, the two systems break about even on an economic basis. (This is somewhat contrary to the general idea, which has always held the resistance-coupled amplifier to be a wasteful and expensive proposition.)

Condensers C_2 , C_3 , and C_4 are included in the circuit, as before explained, to isolate the grid from the plus side of the B battery. Resistances R_2 , R_4 , and R_6 are grid leaks, be-

tween .05 and 2 megohms, the values of which are best determined by experiment. Experience has demonstrated that while the grid leak value is not critical, there are many cases in which variation of this resistance will improve the tone quality of the received signal. One half megohm is about the average proper value.

RESISTANCE COUPLING AND OUR ONE-TUBE REFLEX

AS SUGGESTED early in this article, the single tube crystal detected reflex set, plus three stages of resistance-coupled audio-frequency amplification, is an ideal arrangement. The writer has effected this combination quite satisfactorily in the manner illustrated in Figs. 3, 4, 5, 6, and 7.

Fig. 3 is the circuit followed in detail. Fig. 5 is a plan of the panel. The remaining illustrations are photographs of the completed receiver. It will be noticed that two jacks and two rheostats, controlling the first two and the last two tubes, have been added to the fundamental amplifying circuit. The jacks plug in on the first stage and last stage. Jack 1 will give powerful loudspeaker intensity on local stations, while J_2 may be used for dancing in a medium size hall, and on distant stations. *The last jack should never be used with telephone receivers.* Signals so weak as to necessitate amplification are better enjoyed on a

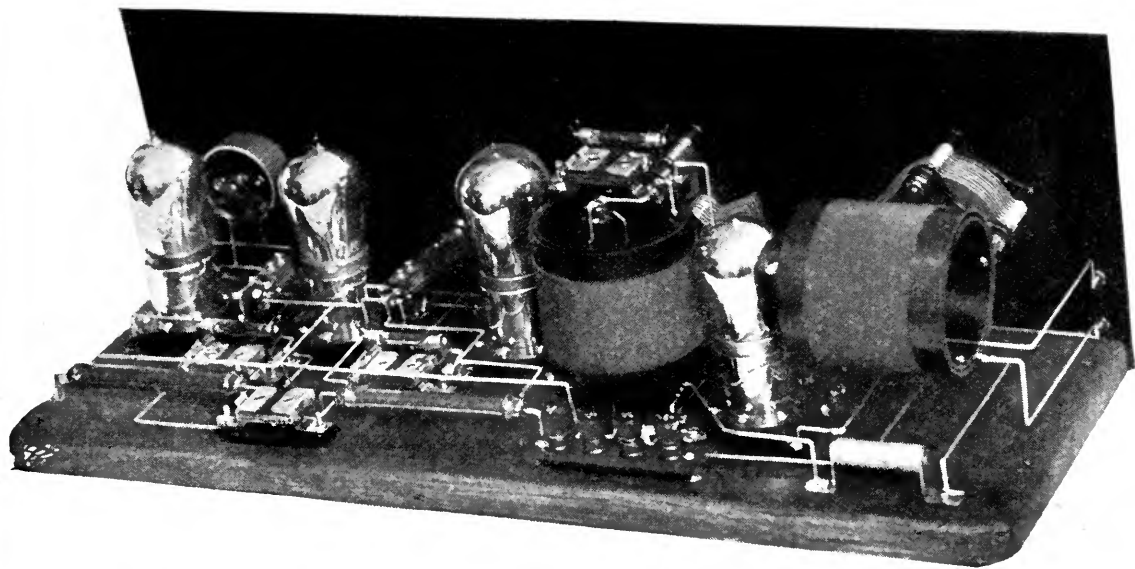

FIG. 6

Behind the scenes. Rewound neutroformer-type coils are used as inductances. This simplifies mounting for the beginner by eliminating machine work

single stage of amplification. Output binding-posts shunt the last jack when closed.

THE PANEL

A STANDARD panel was used—7" x 21". Figure 5 indicates the layout and drilling. All holes, excepting those with specially designated sizes, are drilled to pass a No. 8 screw—the diameter found on dry cells and large binding-posts. The appearance of the completed receiver is greatly improved by graining the panel after drilling—i. e., sandpapering it in one direction, and wiping with an oiled cloth.

THE PARTS

THE required parts are quite plainly shown on the diagram, Fig. 3, and are further listed in the following descriptions:

T₁ and T₂, respectively coupler and R. F. transformer, may be wound by the experimenter as described in the "Knock-out Single Tube" article appearing in the April RADIO BROADCAST, or they may be neutroformer type coils with rewind primaries as suggested in the Laboratory Department of the June number. C₅ and C₆ are variable condensers with about 17 plates, giving a maximum capacity of .00035 mfd. This capacity need only be approximated.

T₃ is a good audio amplifying transformer

having a turn ratio of about four or five to one. Observe the connection initials on the secondary.

Det. is the crystal detector, preferably a fixed crystal such as the Erla or Star, or Celerundum.

R₇ and R₈ are thirty ohm rheostats. Three coupling resistances of 100,000 ohms each (R₁, R₃, and R₅), as well as three grid leaks (R₂, R₄ and R₆) are necessary. These resistances will be treated in more detail later.

C₁ is a small bypass condenser, a Micadon, .0025 mfd. capacity. C₂, C₃, and C₄ may be any convenient capacity Micadon between .0025 and .006 mfds., inclusive. The first capacity was used in the receiver under discussion. C₇ is a stabilizing condenser. A low capacity, .00025, or .0005 at the most, is very effective.

J₁ and J₂ are standard double circuit jacks. Carter jacks were selected by the author for this set.

The reader will observe from photographs 6 and 7, that all condensers and leaks have been mounted in neat clips, which permit instantaneous change of resistances and capacities. This is very desirable in the preliminary operation of the apparatus. It is important that these mountings be of a reliable manufacture, with no resistance losses through the bases.

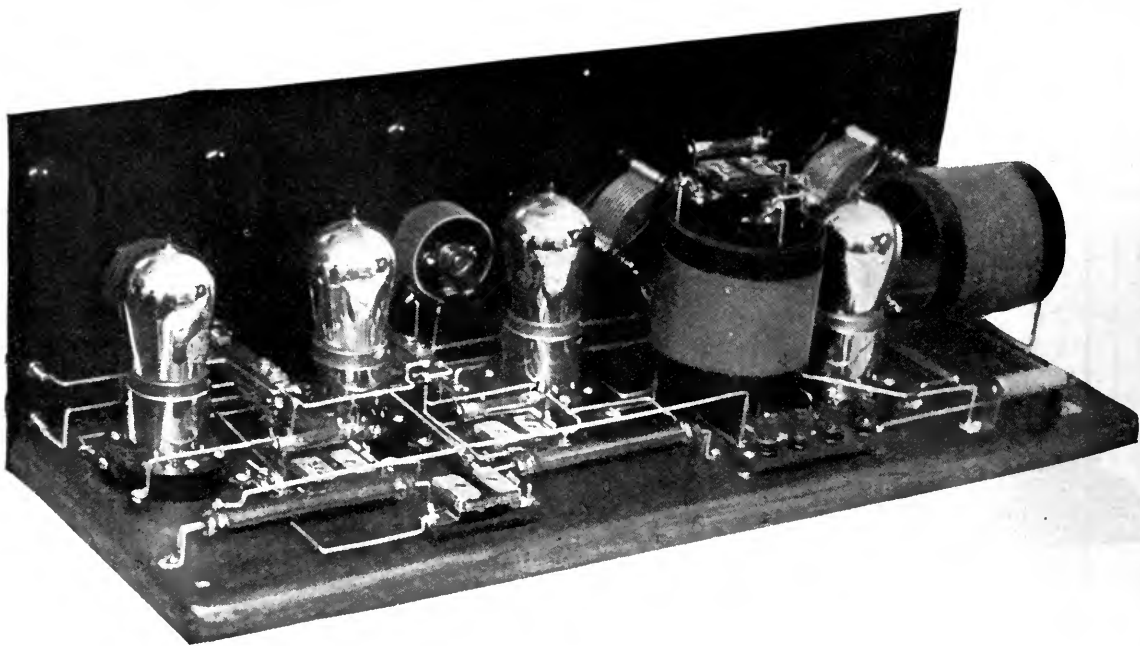

FIG. 7

Note the mountings into which the grid leaks and Micadons are clipped. These permit adjustments which are always desirable, and often necessary

Daven mountings (Daven Radio Company, Newark, N. J.) were used for both condensers and grid leaks. Three grid leak mountings and four condenser mountings are required.

BUILDING THE SET

ALL instruments, excepting T_1 , T_2 , T_3 and the variable condensers, are mounted on the base board, which was a $\frac{3}{4}$ " board cut down to $7\frac{1}{4}$ " x 21."

The photographs show the back of panel layout. The sockets are mounted with the filament connections toward the panel. This arrangement makes possible the most convenient connections to grid and plate.

The filaments are completely wired before the resistance and condenser mountings, the jacks and inductances are placed in their respective positions. The amplifier is next wired, starting with the last step and running toward the antenna. The tuning units are last to be mounted and wired.

Keep all wiring as close to the base as possible. This makes for a neater appearance, more rigid wiring, and facilitates the clipping in and out of condensers and leaks.

THE RESISTANCES

RELIABLE resistances should, of course, be used throughout the receiver. However, reliability is to be particularly emphasized in the case of the 100,000 ohm coupling-resistances and the grid leak to the last tube (R_6).

The coupling-resistances may be any one of three possibilities. The Ward-Leonard resis-

tances obtainable from well stocked radio supply houses, are shown in the photographs, Figs. 6 and 7. Lavite resistances, made by the West-

ern Electric Company, and by the Crescent Radio Company, Jamaica, N. Y. have been found equally satisfactory. The third possibility, and perhaps the simplest is to use a low resistance grid leak. This last, however, must be accurately measured for resistance, capable of passing three milliamperes, and must have a constant resistance. The writer has tested the Daven Radio Resistors (Daven Radio Company, Newark, N. J.) and found them quite equal for this purpose to the more expensive resistances.

This particular make can be obtained in resistances from 50,000 ohms up.

OPERATION

THE operation of the resistance-coupled amplifier is quite consistent and as reliable as the transformer-coupled type. The only adjustments that may be necessary to secure the most efficient operation of the amplifier, is the change in the stabilizing condenser, C_7 and the grid leaks (not the coupling resistances).

If, on very loud signals, using the full amplification, distortion or blasting is noticed, reduce the resistances of the grid leaks in the last two tubes. In the receiver just described, the writer uses 2. meg., .5 meg. and .05 meg. in the respective cases of R_2 , R_4 , and R_6 .

On local stations, it may be desirable to eliminate the high voltage tap, operating all tubes at a plate potential of ninety volts or less.

List of Parts Used in Making This Four-Tube Knock-Out Receiver

Two neutroformer type coils with condensers	\$14.00
Four General Radio* sockets	4.00
One Amertran* audio transformer (5 to 1 ratio)	7.00
Two General Radio* rheostats (20 ohms)	2.50
One Pryatek* fixed crystal detector (see article)	1.25
Two jacks75
Nine Eby binding-posts	1.80
Two Pathe* dials	1.20
Three grid leaks (see article)	1.50
Coupling resistances (see article) at \$5.00	15.00
Three Daven grid leak mountings*	1.20
Three Daven clip condenser mountings	1.20
One panel, 7" by 21"	1.75
Four Dubilier Micadons .0025 mfd.	2.00

Approximate cost \$55.65

*Other high grade makes may be substituted for the designated manufacture with equally good results.

USING VARIABLE GRID LEAKS

THERE are some variable grid leaks now on the market which have a minimum resistance of approximately 50,000 ohms and are capable of carrying the current in the plate circuit of a standard tube used in a resistance coupled amplifier. Variable grid leaks having a minimum resistance above 100,000 ohms, or incapable of carrying a plate current of approximately two milliamperes, should not be used as the coupling resistors, but any good variable grid leak may be used in place of the fixed grid leaks R_2 , R_4 , and R_6 .—THE EDITOR.

Some Remarks in Passing

By J. P. McQUAIDE

Vice President, Moon Radio Corporation

RECEIVING distant stations depends greatly on weather conditions. If you receive many different stations one night and not the next, don't blame your set. If you do not think the trouble is in the weather, look at your batteries. They may be run down or one of your tubes may be losing sensitivity. As a general rule there is nothing in a radio set to wear out and once it is working satisfactorily, the trouble is usually in either the tubes, batteries or weather conditions.

Don't use any higher voltage than is necessary on your B batteries, as the more voltage you use the faster your batteries will give out.

Some people think that because their tubes light, they must be all right, but this is not always the case, as the filament of your tube may light long after your tube has become defective. Every so often, it is a good plan to take out your tubes and clean the points. Good electrical contact is highly important in the tube socket. Particular trouble may be encountered at the plate or grid socket contacts, and this is the hardest to find since even if the pins are not making contact, things look all right.

If you have just bought a set and you know

it is of good manufacture, do not become dissatisfied because you have not obtained the results that some friend of yours is getting.

In large cities where there are many so-called dead spots, it is quite possible for a set to work much better in one room than it does in another due to the steel construction in the building. Try moving your set from one room to another, if you are not getting good results.

A voltmeter for your B battery registering 0-50 volts, and also a hydrometer, are good accessories to have around.

Don't try to make a lot of noise with your set. Good clear reception with less volume is far better than reception with distortion and great volume.

If you are getting good results from your receiving set, write and tell the manufacturer. He will be very glad to know it. If you are not getting the proper results, he will want to know that too. Perhaps he can help you.

Receiving sets are becoming easier to operate, and the manufacturers are doing all in their power to help you enjoy radio concerts. Receivers are not automatic, however, and should be given some care and not knocked around from place to place.

*V*ERITABLE multitudes of radio listeners in the eastern and central parts of the United States who count that Sunday lost when they do not hear "Roxie" and his gang from the Capitol Theatre, New York, will be much interested in James C. Young's excellent story about "Roxie" (S. L. Rothafel), his gang, and his theories, which we will print in July.

What's in a Name?

A Brief Guide Book to the Radio Gallery of Names, Telling Why "Dynes" and "Plexes" Need Not Be Greek to Almost Everyone

By JULIAN KAY

If you are new to radio—or at least a present stranger to radio theory, the series by Zeh Bouck, "Various Circuits and What They Mean" is well worth consulting. In this magazine for December, 1923, appeared the first of his articles on How to Analyze a Diagram. In January, 1924, Mr. Bouck's article explained what inductance is and how it is used. The February article explained how radio circuits are tuned. "What Makes the Wheels Go 'Round" W. Van B. Roberts' serial explaining radio theory should also be consulted. It began in March.

OF ALL the pests the worst is probably the chap who has a positive mania for radio. He follows you around talking about super this or dyner that. He has a habit of pushing you into a corner to tell you of the latest tricks he has played on his Neutroreflex. He knows more circuits than you can shake a stick at; he eats, sleeps, and orates radio.

Do you know this chap? He is always worrying about his plex, or his auto, or his dingus circuit. He rushes madly from one radio fad to another, speaking hazily about "quality" or "radio-freq." His usual conversational ability can be measured by:

"Say, I tried out those Fussiform coils on my Superwhoosis last night. I had twenty-eight turns of double covered green silk magnet wire on the secondary and a double naught two five condenser across—" and so on *ad libitum* until you go.

Suppose for instance that you were a master of the violin, that you loved your instrument, that you knew it better than anything else. Suppose that you had made it a lifelong companion, that it soothed and piqued you and

gave you immeasurable joy and pleasure. With fellow devotees of the violin you shared your secrets and your dreams.

And then some morning suppose that you found everyone talking of your violin in the most off-hand fashion, not as the instrument that you loved but as a "fiddle"; and that people seemed more interested in the fact that it was made of Spanish cedar and LePage's glue

than in the beautiful tones with which it responded to your touch.

SUPER-FIDDLES AND
FIDDLE-DYNES

SUPPOSE even, that the big brothers of the violin were mentioned as super-fiddles and fiddle-dynes instead of their proper names; that everyone could play them as easily as though they were tin horns; that everyone talked in the most glib manner about species of violins of which you had never heard.

In fact, if you suddenly awoke to the fact that your hobby was no longer an in-

dividual affair, but that the whole world owned it, a world that thought you out of date—how would you feel about it?

Do you see how the old timer in radio feels about all this business of names, and new

What Does That Mean?

Is an often repeated question addressed to those who know and those who seem to know, more than the rest of us about radio. The answer may be correct or it may be some hazy attempt at explanation that leaves the questioner in a greater confusion and uncertainty than ever. And when the question turns to receivers and their names, well indeed can the question be "What Does It Mean?" There are many who recite the various name-tags glibly, knowing precious little whereof they speak.

This article attempts to sort out and classify the receivers in present use, to show what they are, and how they are electrically related, and what they are designed to accomplish. No effort is made to give a technical or even popular explanation of their working, for that is task enough for a book. This series aims to cast at least a faint light in the present dark forest of ponderous hyphenated radio names.

—THE EDITOR.

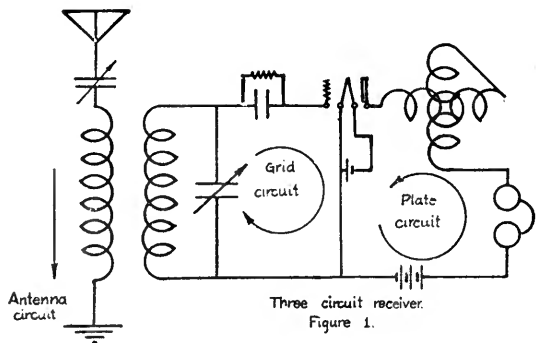

circuits, and the smug acceptance with which radio is viewed to-day?

Or, if you are a new comer, are you bewildered by the claims of the various dynes and plexes and supers and the personal monuments like the "Jones" or the "Smith" circuits?

To classify the types of receiving circuits now being used, the Family Tree on page 112 may be useful. It will be seen that there are three broad groups of radio receiving equipment, and it may be said at once that all of the modern types may be found there, or may be a hybrid product of two or even all three of these groups. So when your friend says that he had a new circuit see how it fits into the Circuit Family Tree, and if it cannot be found there, if it is not a detector or an amplifier, rush your friend to the patent office, for he has something the world needs.

ALL RECEIVERS MUST BELONG TO ONE OF THREE CLASSES

THESE three great groups into which all receiving equipment naturally falls are dependent upon each other, and a really good outfit is a proper combination of apparatus from each of the groups. The name it bears is no criterion of its effectiveness as a receiver. Indeed "a rose by any other name would smell as sweet."

The first requisite for a receiving set is a detector serving the same purpose as our own physical organs for "detecting" the sounds that exist in the air, organs we call ears. Now everyone knows that there are sounds that are too weak for us to hear, and that we can remedy our inability to detect these minute sounds by proper means of magnification, say by an ear trumpet. If our human organism possessed a device between the ear and the brain for again amplifying the sounds that the ear detects, we would have a more or less

complete analogy for the three groups of radio receiving equipment.

Radio-frequency amplifiers magnify the incoming energy before it is passed through the detector, and following the detector, come audio-frequency amplifiers which again magnify the energy.

ABOUT DETECTORS

DETECTORS naturally fall into two classes, non-regenerative and regenerative. The first group comprises the simplest of all receiving circuits. Crystal detectors are very old, going back to the earliest days of wireless telegraphy. The simple audion connection was used for a considerable time before Armstrong demonstrated his remarkable discoveries leading to the regenerative detector.

The last two years have seen the advent of vacuum tube detectors on shipboard, but on many vessels at the present time, the operators still wrestle with old "catwhisker" crystals. Among the amateurs, however, the crystal of the past few years, is as good as dead, and would be completely out of date to-day were it not for the recent, broadcasting development.

The non-regenerative detectors are marked by certain inherent disadvantages, but contrary to common opinion have other advantages which are becoming more and more important.

A crystal or simple non-regenerative tube detector without some means of amplification will not respond to signals from very great distances nor will it give much volume. On the other hand, the quality of music or speech produced by such a detector is far better than the usual regenerative equipment is capable of producing, particularly when handled by one unaccustomed to tuning it. With a stage

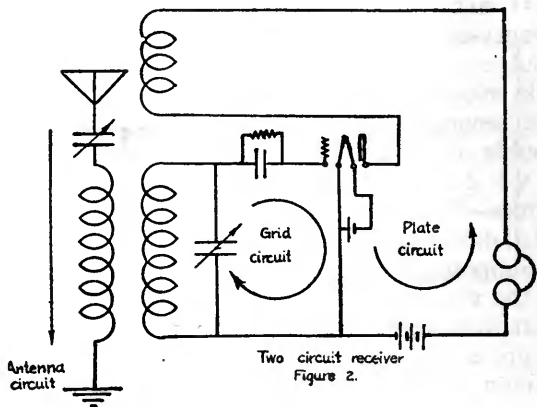

or two of radio-frequency amplification to boost the incoming energy, and a stage or two of audio-frequency amplification to bring up the signals to the required volume, a simple non-distorting detector is unequalled.

The outstanding features representative of this group are, that they are

1. Non-distorting.
2. Of low cost.
3. Capable of short distance reception.
4. Of low upkeep.
5. Simple.
6. Non-selective.
7. Non-radiating.

The principles underlying the regenerative receiving circuits are the foundations upon which present day radio is built. Were it not for what vacuum tube experts call "regeneration"—whence comes the name of these receivers—radio broadcasting would probably not exist to-day.

WHERE THE VACUUM TUBE COMES IN

THIS discovery seems simple in the light of our present knowledge. Suppose we have a device that has more energy in its output than in its input circuit. If some of this excess energy is fed back into the input, it will reappear at the output, amplified by the action within the device. If the excess output is sufficient to make up for the losses due to resistance in the circuit, continuous oscillations are built up and we say that the system "oscillates."

The immediate result is a remarkable increase in signal strength due to the fact that

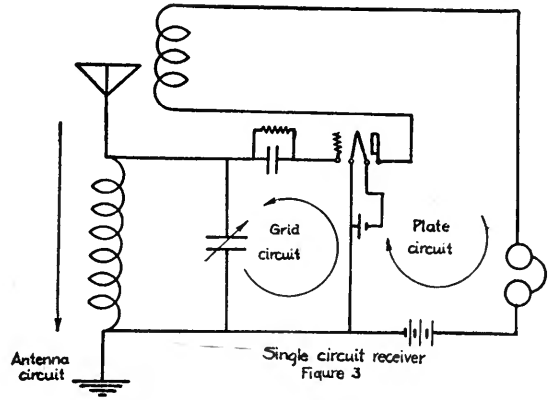

regeneration is apparently a method of decreasing resistance to a very low value, which permits large currents to flow. Another important result is the increase in selectivity also due to the lowered effective resistance.

In general it may be said that regenerative receivers are highly sensitive, reasonably selective, giving considerably greater strength of signals than non-regenerative detectors. On the other hand, this type of detector is critical in its adjustment, is likely to distort so that music and the voice are not reproduced accurately and pleasantly. The great objection to this type of detector is its certainty to disturb fellow listeners by its self radiation unless carefully handled.

At the present time the tendency seems to be away from regenerative detectors and toward radio-frequency amplification, so that the future may see the birth of new receivers utilizing other methods of detection giving the same sensitivity but none of the distortion or interference defects of regenerators. The Sodian tube is a decided step in this direction.

ONE WAY "NEW CIRCUITS" AND "NEW" NAMES START

IN ACTUAL practice the plate circuit (output) is coupled back to the grid (input) either through a resistance, an inductance, or by means of a condenser. In fact if the experimenter is ambitious and wishes to combat all manners of coupling he may use combinations of all of these methods. And each time that someone "discovers" anew these coupling methods a new name is given it.

It will be noticed that the chart divides regenerators into several groups depending upon the complexity of the equipment. Any complete receiving set must comprise three

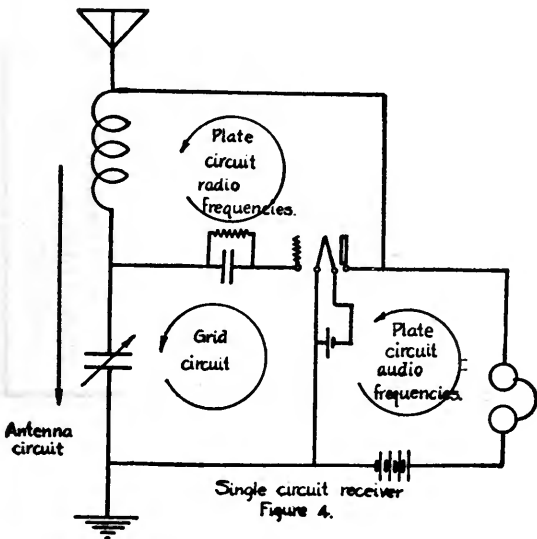

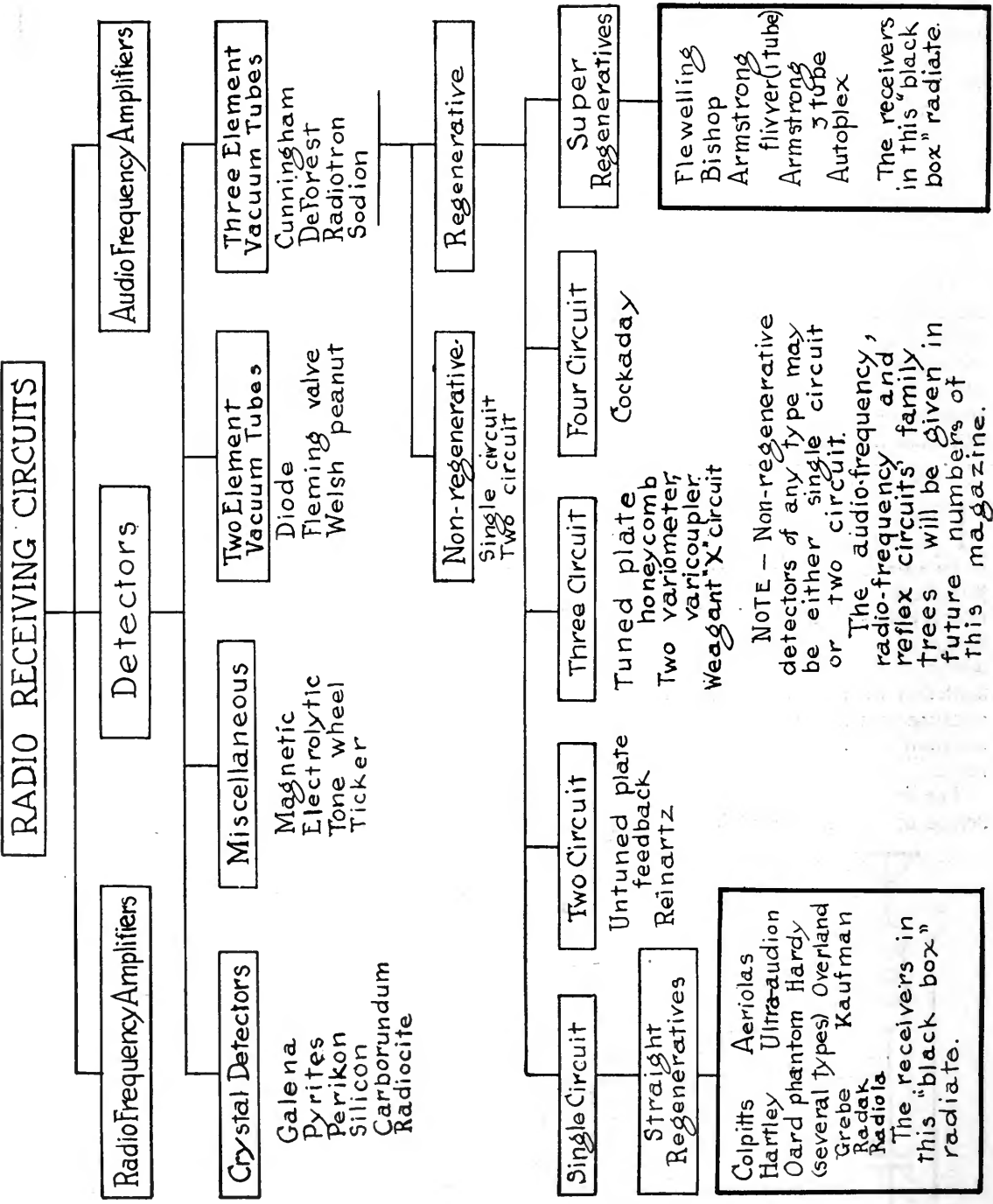

NOTE - Non-regenerative detectors of any type may be either single circuit or two circuit. The audio-frequency, radio-frequency and reflex circuits family trees will be given in future numbers of this magazine.

radio-frequency circuits: the antenna and ground, the secondary or input of the detecting device, and the output. If the output is not tuned, that is, if there is no attempt to resonate it with the radio-frequency signals, the system becomes a two-circuit tuner. If the antenna to ground circuit is combined with the input, the combination is known as a "single circuit" receiver.

Of the latter, RADIO BROADCAST has already said plenty. This receiver is like the neighbor's dog that howls under your window at the moon. It causes the horrendous squeaks and howls; the little fellow around the corner that swishes across your wave, breaking into your concerts, and offending your musical ears. In England it is unlawful to do anything with one of these outfits except, as someone has suggested: "Use it as an anchor."

On the circuit Family Tree they are enclosed in a black box of mourning and they should be dead.

WHY THE MULTI-CIRCUIT SETS ARE GOOD

THE two-circuit tuner is a great improvement over the single circuit owing to its greater selectivity.

The three-circuit outfit in which the plate radio-frequency path is also tuned is naturally the most efficient of all, for oscillations occurring in this circuit may be controlled—a feature which the simpler systems do not possess. In connection with this type of equipment it must be said that close coupling between the antenna and secondary circuits may produce just as malignant interference to one's neighbor as any improperly operated single circuit regenerator.

In these various schemes, it does not matter whether an inductance or a condenser is used for the feed back or the tuning, the process is

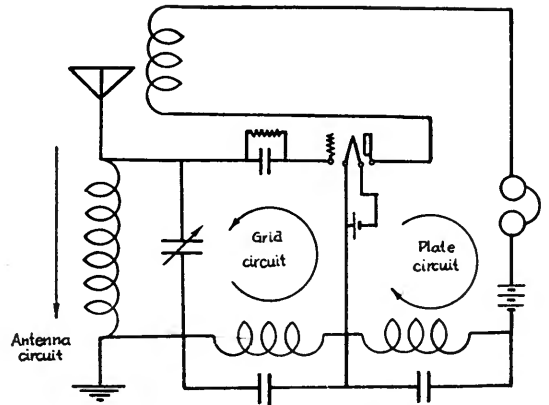

Armstrong flivver circuit
Figure 5.

one of obtaining resonance or of conveying energy from one circuit to another. For instance the "X" circuit in which the plate is tuned with a fixed coil in series with a variable condenser in place of the usual variometer is still a tuned plate arrangement.

In fact the capacity element of a complete radio path may not be apparent at all, but may exist within the tube, or as distributed capacity of windings, or as the capacity of the antenna to ground.

The ultra-audion has the input circuit attached directly to the plate; the "tickler" outfit uses a coil in series with the plate and placed near the grid coil to affect the feedback; the Reinartz employs a condenser between grid and plate—and there you are. They all do the same thing but in a different way.

The Four-Circuit tuner is apparently an adaptation of the ultra-audion in which an extra absorption circuit is placed near the grid inductance. The idea is to extract enough energy from that circuit to prevent oscillation with its accompanying distortion. It is better than the straight ultra-audion on this account.

The Reinartz circuit was developed by a prominent amateur for use in receiving continuous wave stations operating on short wavelengths. It is most efficient when the tube oscillates, and is simple to adjust. The feedback control is nicely adjustable.

When improperly handled it has a tendency to radiate.

SUPER-HETERODYNE AND SUPER-REGENERATOR ARE THE ONLY NEW DEVELOPMENTS

THE latest application of regeneration, the super-regenerator is a member of the type of detector under discussion. The principle

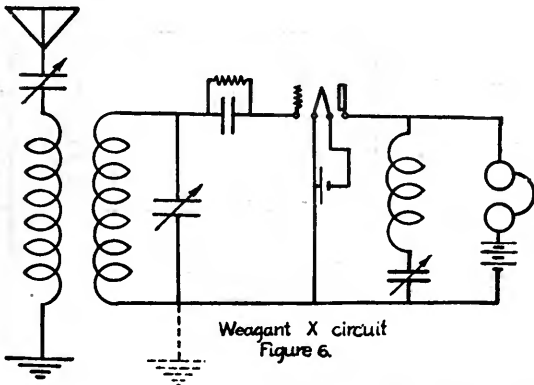

Weagant X circuit
Figure 6.

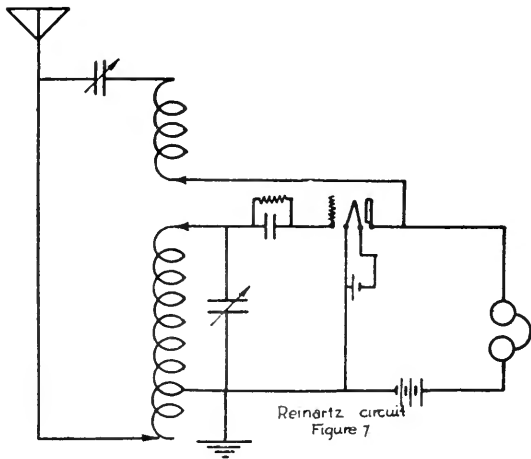

is rather unique and the development of this system marks the only "new" thing that has appeared since the super-heterodyne.

As any one knows who has operated a regenerative receiver, the most sensitive operating condition is at the point where the tube is about to break into actual oscillation. Many schemes might be devised for actually letting the tube oscillate a small fraction of a second, and then to shut it off. This is what was actually accomplished in the super-regenerator. As usual there are several methods of carrying out this idea, and many of the "trick" circuits that exist to-day may be traced to some obscure super-regenerator function.

In practice, this type of receiver proves to be noisy and critical, and it is one of the most powerful radiators. It has not proved to be of great value in the reception of music, although it is useful in code receivers.

Without a doubt the regenerative receiver is one of the most sensitive and efficient devices ever discovered, but its use in radio seems limited to the time when equally efficient radio-frequency amplifying systems are developed—schemes which will be discussed in a future article. Under this head fall the neutrodyne, the superdyne, and the super-heterodyne.

In order to get sufficient energy from any type of receiving equipment to operate a loud speaker it is necessary to use one or more stages of audio-frequency amplification. To increase the range of a given receiving set, a stage of radio-frequency amplification may be added before the detector, and when one adds this equipment it is a fairly simple matter to make the extra vacuum tube do double duty—in other words to reflex it. Reflex systems in

which the audio and radio amplifiers are combined are the most economical arrangements used to-day, and as usual are of several varieties, each with a different name. This group will be discussed in subsequent articles.

ABOUT RADIO-FREQUENCY AMPLIFICATION

MANY names have been applied to the many schemes for amplifying radio-frequency energy. Sometimes these names signify what is going on in the device, but usually they are colorful handles added to otherwise colorless circuits. It is much easier to invent a new name for an old circuit, than to invent a new circuit. The next article in this series will develop the radio-frequency family tree, and show how the various methods work.

By properly designing a radio-frequency amplifier and carefully *neutralizing* it, one can add considerable volume to the signals. This is contrary to the common supposition that a noticeable addition of volume can only be attained by audio-frequency amplification. The two-tube receiver described in RADIO BROADCAST for April and May is an excellent example of what one can do with a small amount of equipment. Here is a detector, a radio- and an audio-frequency amplifier, a "neutrodyne" and a "reflex"—all with two tubes.

In following articles in this series, the various circuits which involve the use of radio-frequency amplification will be discussed. The radio newcomer should preserve these circuit "family trees", for they will help him analyze the many circuits which plague his bewildered eye.

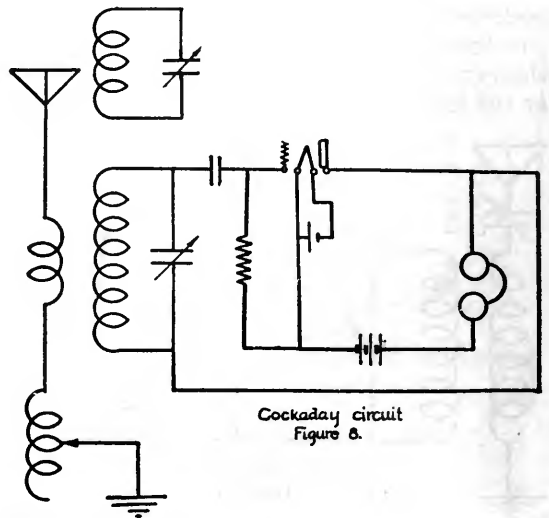

The Inside Story of the British Broadcasting Experiments

How Success Came After Many and Long Experiments to Link America and Great Britain, by One of the Staff of 2AC at Manchester

By W. J. BROWN

Metropolitan-Vickers Company, Manchester

SO MUCH interest has been aroused by the recent American rebroadcasting tests that the following account of the preliminary experimental work which was necessary before the tests could

be conducted should be of some interest. It is probably not generally realized that the relaying of KDKA, the Pittsburgh station of the Westinghouse Electric & Manufacturing Company, was only rendered possible by a tremendous amount of experimental work between this Company and the Metropolitan-Vickers Electrical Company of Manchester. There was no mystery about the excellent results which have been obtained on 100 meters. These were in fact the culmination of plans which were made many months ago.

The Metropolitan-Vickers Company is in very close technical association with the Westinghouse Company, and several months ago it was agreed that a combined attempt should be made to relay the KDKA broadcasting programs in this country. The Westinghouse Company had been experimenting with short wavelengths around 100 meters and had found that they promised well for long-distance

reception, though of course this is all against the theory of excessive absorption on short wavelengths. In September, 1923, they commenced experiments with the Metropolitan-Vickers Company by transmitting their ordinary broadcast programs on 100 meters as well as on their normal broadcast wavelength of 326 meters. The Metropolitan-Vickers Co. built up a 100 meter receiver and listened to the transmissions at their experimental station at Altrincham in Cheshire.

WHAT 100 METER WAVES WOULD DO

IT WAS immediately apparent that the 100 meter transmissions came over the Atlantic better than the 326 meter wavelength. The chief improvements noticed were firstly, greater consistency of results, secondly, freedom from interference by spark stations, "mush" and static, and thirdly, the comparatively small amount of fading experienced. As regards consistency of results, the improvement was particularly noticeable, and it was found possible to receive signals much earlier in the night than was possible with the 300-500 meter American transmissions.

The Future—Which Way?

It is manifestly impossible for every radio listener to own a highly sensitive receiver. And it is also true that as radio grows older, broadcasting will be more used in politics, in government, and all branches of the national life. So it is that the long-visioned ones in radio have wondered how it is economically and electrically possible to bind together some of our powerful and important broadcasting stations located at strategic points in the country, so that an event of national importance could be broadcast nationally. Most of our readers know of the recent successful experiments which have taken place within the last six months.

Now there are two ways to link broadcasting stations. One is by direct land wire, and the other is by radio itself, using extremely short wavelengths. In this country, the American Telephone and Telegraph Company has done much with the land line method, while the Westinghouse Electric and Manufacturing Company has taken the opposite course and done a great deal of research with transmission over long distances with short waves. We described these experiments from the American angle in our February number. This is the English side of the story.

—THE EDITOR

The experiments being so far successful, the Westinghouse Company built a new transmitter operating at nearly 30 kilowatts input. This transmitter represents absolutely the latest radio engineering practice. It employs special high-power tungsten valves with an elaborate system of water-cooling, whereby quite a small valve can be made to handle an enormous amount of power. Most elaborate precautions are taken to prevent slight changes of wavelength which at the exceptionally high frequency of 3,000,000 cycles per second would have a very serious effect. The antenna system is designed to have absolute rigidity, as are the high frequency connections of the transmitter itself. The inductances are wound on rigid formers and as a final precaution the whole of the high frequency portion of the transmitter is mounted in a framework suspended by springs.

Statements have recently appeared in the press

to the effect that KDKA has been making no special effort to broadcast their signals over the Atlantic, and also that their 100 meter transmission is of lower power than that of a British Broadcasting Company station. When it is realized that KDKA has been working with Metropolitan-Vickers for months past, and that they built a transmitter specially for transatlantic work which is *probably greater in power than all the British Broadcasting Company stations put together* the inaccuracy of such statements will be appreciated.

The first tests on the new transmitter were made in October, 1923, and naturally it was found that signals were coming over a good bit more strongly than before. Other troubles became evident however, chief of which was "night distortion" which is caused by slight changes in the carrier frequency of the transmitter, together with changing propagation conditions. In many cases this distortion was

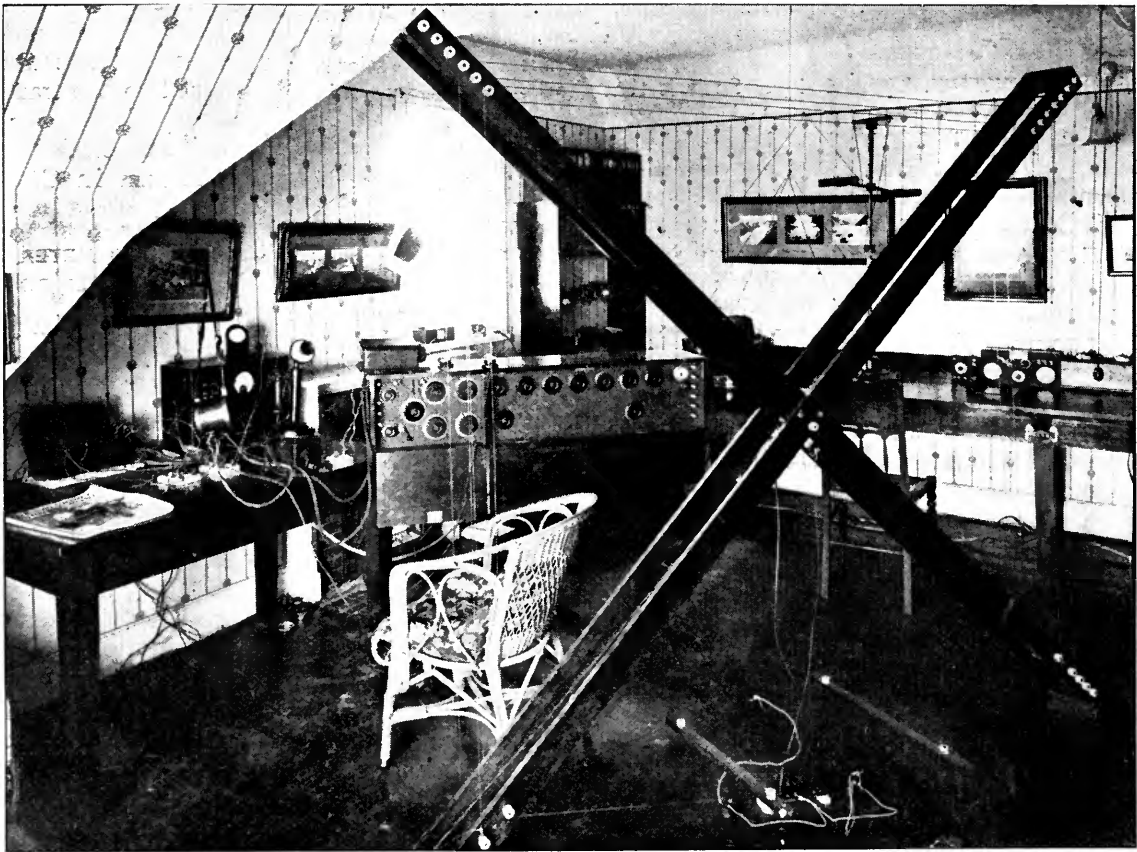

WHERE AMERICAN BROADCAST PROGRAMS ARE HEARD ALMOST NIGHTLY

The extremely sensitive receiver at the Trafford Park Laboratories of the British Broadcasting Company near Manchester. The six foot loop in the foreground is used constantly in receiving 94 meter waves from KDKA, and, recently, the 104 meter wave of WGY. A wire line connects this station with the operating room and studio of the Manchester station 2 AC

so bad that speech was rendered quite unintelligible.

It must again be emphasized that, working with wavelengths as short as 100 meters, a very much greater constancy of wavelength is required than with the 300-500 meter transmissions, and also this constancy is much more difficult to obtain.

Many experiments were carried out with a view to eliminating this trouble. These experiments were carried on usually in the early (or rather, late) hours of the morning after the American broadcast program had ceased, and special forms of modulation were employed for the purpose of analyzing the effect. Great difficulties were met, particularly at the transmission end, and these resulted in an almost continuous flow of cablegrams between the two companies. In the end, on December 27, 1923, a fairly good transmission through was achieved, and on the following day rebroadcasting of KDKA to listeners in Great Britain was an accomplished fact.

During the following seven or eight days the Metropolitan-Vickers Company carried out a series of rebroadcasting tests, so as to gauge the possibilities of their system as it then stood. The repeating was done from the Company's station 2AC at their research laboratories, Trafford Park, Manchester. An experimental $1\frac{1}{2}$ kilowatt transmitter was employed, operating at a wavelength of 400 meters. Reception was still carried out at the Altrincham Station. The two stations were connected by land-line.

mine the most satisfactory method of reception. During the whole of the relaying period, however, a frame aerial some six feet square was used for picking up the signals while the receiving set employed a number of high frequency stages varying from six to twelve according to the prevailing conditions of reception. After detection, the signals were passed through two stages of low frequency power amplification before passing them on to the line leading to the microphone transmission.

At the beginning of the week, the whole of the controlling and announcing from Altrincham was done over telephone lines, but this was found to be rather unsatisfactory since there was no suitable non-resonant room for speech purposes at the Altrincham station; hence these functions were transferred to



© Barratt's, London

THE MANCHESTER EQUIPMENT

CAPTAIN A. G. D. WEST

DURING the preceding two months many different forms of receiver and various antenna systems had been tried out, to deter-

mine the most satisfactory method of reception. Captain West has supervised the successful rebroadcasting of American programs from WGY and KDKA on a number of occasions. "We have some difficulty in regard to distortion," says Captain West, "The announcer is usually quite intelligible, but in some speeches, not a word can be understood, and this is perhaps when they are an "outside broadcast" One of our chief troubles is from French amateur transmitters working on about 100 meters. Some of them spend their time tuning up and down for hours on end"

Trafford Park before the end of the week. In order to keep a check on the quality of the landline transmission from 2AC, a 400 meter receiver was rigged up at Altrincham. The "control operator" was equipped with a pair of phones which he could connect at will either to KDKA direct or else to KDKA via 2AC and thus he could immediately detect any transmission or line faults.

A portion of the receiving station is shown in the accompanying photograph. The frame

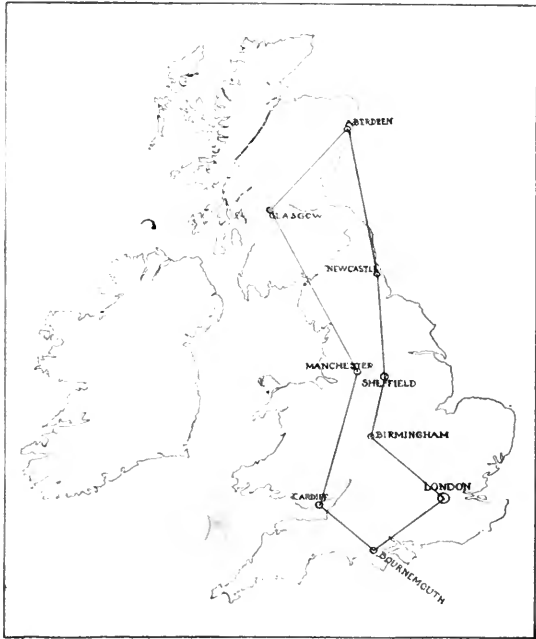

THE NINE BRITISH BROADCASTING STATIONS are connected by land line to the central London station

antenna is seen in the foreground. Behind, to the left, is seen the control and announcing table and the low frequency amplifiers. Immediately behind the frame antenna is seen one of the receiving sets.

During the period of approximately one week the Metropolitan-Vickers Company succeeded in relaying the Westinghouse transmissions for an aggregate time of 18 hours. In two or three cases relaying commenced about 11.30 Greenwich Time, but the best results were undoubtedly obtained between the hour of 4 A. M. and 7 A. M. as had been anticipated from previous results. In fact one or two of these early morning transmissions were almost perfect in their reproduction—nearly as good as a first hand broadcast transmission.

ARLINGTON SIGNALS TWICE RETRANSMITTED

DURING the week a complete American program was successfully relayed right from the first item by the Westinghouse Band at 11:20 P. M. up to the relaying of the Arlington time signals at 3:00 A. M. The relaying of the Arlington time signals was in itself something of a novelty, since it reached the ears of British listeners through no less than three stages of transmission. The signals, which are the American equivalent of the famous Paris time signals, were transmitted from Arlington on a wavelength of 2650 meters at 10:00 P. M. New York time. They were picked up by the Westinghouse Company at Pittsburgh, 200 miles distant, and sent over the Atlantic to Manchester on the 100 meter wavelength, who received them and transmitted them for the third time on their 400 meter wave at 3:00 A. M. Greenwich Time. (Greenwich time is 5 hours later than that in New York).

Anxious to obtain all possible information and experimental data concerning the relaying, the Metropolitan-Vickers Company asked for reports, and got them. They were numbered first by hundreds and then in four figures. With scarcely an exception, they were all complimentary, most of them enthusiastically so. Many of these reports came from the Continent, some of them from as far off as Switzerland and even Italy. When it is considered that the power input at 2AC is somewhere about half the average power of a British Broadcasting Company station and that the actual relaying of KDKA was clearly heard at these distances, the results of the experiments were very gratifying. It has been possible to reply by post to only a very small percentage of the reports received, and the Metropolitan-Vickers and Westinghouse companies would like to take this opportunity of recording their thanks to all those listeners who have been good enough to send in their reports and comments.

A few details of the ordinary broadcasting activities of the Westinghouse Company may be interesting. In November, 1920, they opened the pioneer broadcasting station of the world, KDKA, at East Pittsburgh. The first transmitter was of comparatively low power—100 watts were delivered to the antenna. This was increased by stages to its present value of 1000 antenna-watts, corresponding to

a D. C. input of four or five kilowatts. The main studio at KDKA is situated half a mile from the transmitting station. There are also two other studios in the city, 14 miles distant, all of which are elaborately equipped. Land-line transmissions are an important feature; there are 45 permanent landlines covering an area of 225 square miles. These take in every church, theatre, public hall, and auditorium of any pretensions in the Pittsburgh section.

SOME CONCLUSIONS ABOUT SHORT WAVE BROADCASTING

IN CONCLUSION it is interesting to compare the results obtained with this 100 meter experimental transmission with those which might be expected with the ordinary 300-500 meter American broadcasting. As indicated earlier in this article it proved possible to relay the 100 meter signals for 18 hours during little

more than a week, whereas in all probability sufficiently good reception of the 300-500 meter signals for relaying purposes would not be obtained for more than 2 or 3 hours per week. Thus it may be claimed that these experiments with the Westinghouse Company have increased the chances of American relaying probably about ten times. Also they have rendered it practicable to start such relaying at about 11:00 P.M. during the winter months, as compared with the impossible hour (for most people) of 1:00 or 2:00 o'clock in the morning.

Of course perfection is not nearly reached, but some of the greatest difficulties which existed have been largely overcome, and with further developments the relaying of intelligence and entertainment from America may in the fairly near future become a matter of everyday fact.



© Keystone

THE HOTEL SAVOY BAND

—a well known dance orchestra from a well known London hotel, whose excellent programs have been broadcast for the special benefit of American listeners from 2 LO and the other eight BBC stations



What Does the Public Want in Radio Music?

BROADCAST directors seem to be losing much sleep worrying over the question, "What does the public want in radio music"? In their well-intentioned attempts to find a solution to this problem they send out questionnaires, or they ask at the end of a program if the listeners will please be so very kind as to let

it be known by letter what numbers they most enjoyed. "Only through such means," comes the explanation, "can we give you what you want."

One would think from this that until radio came into existence the American public had given no indication of what it wants in mu-

sic. On the contrary this question was quite definitely answered—so many people believe—long before a broadcast station was thought of.

In order to find a partial answer, broadcast directors might examine the attendance of concerts and opera and thus find out what kind of music the public pays to hear. They might well listen . . . as one among these audi-

ences and note how the music is received.

Through these means an idea can be gained of what large numbers of people want in radio music. For one's musical taste does not change simply by tuning-in a receiving set. Many people listen over radio for the same kind of music that



© Underwood & Underwood

IGNAZ FRIEDMAN

To hear such an artist as Mr. Friedman over the radio wipes out the memory of many mediocre performances sent through the air. The New York recital of this internationally famed pianist was broadcast by station WEA F



—Nicholas Muray, New York

EVA LE GALLIENNE

This picture shows this famous young actress as she appears in "The Swan" at the Cort Theater, New York. Miss Le Gallienne was recently introduced to a radio audience through station WOR. After giving a short talk, she read some of the most widely known of the poems written by her father, Richard Le Gallienne. From the picture, one concludes that those who could hear but not see Miss Le Gallienne lost as much as they gained

they have long enjoyed through the established concert channels.

To facilitate knowledge of what sort of music a large public pays to enjoy, here are some facts.

There are in this country ten or a dozen permanently established symphony orchestras of the first rank, maintained solely for the purpose of presenting only the best in orchestral music supplemented at times by soloists capable of playing or singing works of a standard in keeping with the rest of the program. There are about forty other orchestras maintained for the same purpose and all steadily advancing into the same rank. This means that in fifty or more cities, and in the communities adjacent to these cities, there is a public eager to hear the greatest music ever written. For the foremost instrumental works of the worlds' foremost composers may be found in orchestral literature.

To hear these orchestras and other musical attractions of equal standard the American public spends more each year than for attendance at all the sports combined, even including those years when championship prize fights are staged.

The music students who are scattered all over the country pay millions of dollars yearly for serious musical instruction. Their teachers add to the aggregate of these figures by themselves spending money to study whenever possible under the great concert artists who, at stated periods, conduct master classes.

There is scarcely a college of any importance throughout the entire land that does not maintain a music department.

In well nigh every city, and also in large numbers of towns, pupils in the public schools are given opportunity to study music under

expert instruction, this study including also classes in musical appreciation so that the pupils may be made familiar with the classics. In Cleveland, Ohio, for example, thirty members of the Symphony orchestra—and each one of these thirty a master on his instrument—give instruction to school children, the cost of these lessons being paid out of the Community Chest.

In practically every city where a symphony orchestra is maintained, special concerts are given for children of school age, and although only music of high standard is played, the difficulty is to find accommodation for all who want to attend. In New York, Walter Damrosch, who for years has given such concerts,

was obliged last fall to transfer them from Aeolian Hall to Carnegie Hall of far larger capacity. Philadelphia, Cincinnati, Detroit, Chicago, Minneapolis, and San Francisco, are a few among the other cities where the attendance at such concerts is limited only by the seating capacity of the auditorium.

America leads all the other countries in its patronage of music. This is why every concert artist who can pay his way across the Atlantic comes here with the hope of making a living.

Nor are these artists heard only in the cities. Towns of no more than a few thousand population engage, year after year, some of the best talent that good music

may be heard rightly presented. And when these people cannot hear an artist in their own town they journey at much expense to some near-by city to enjoy this privilege when the opportunity to do so presents itself.

The sum total of the money thus spent each year for good music in the United States is estimated by some authorities in the billions.



—Moffett, Chicago

CLAUDIA MUZIO

One of the greatest among living operatic sopranos and now with the Chicago Civic Opera Company. She has been heard in solos over the radio and affirms that she enjoys singing for her unseen listeners as much as they seem to enjoy hearing her, judging from the letters she has received from these listeners. Mme. Muzio's broadcast performances have been given at the Zenith Station now operated by the Chicago *Tribune* (WGN)

Be that as it may, the amount is quite sufficient to prove to every broadcast director that there is a large public that wants the best music and nothing but the best over the radio. By this is not meant only the old classics, but also the lighter works with which good musical literature abounds.

On the other hand, enormous sums are yearly spent to hear the so-called popular music, some of which is very good of its kind and has its legitimate use as a means of entertainment. Still larger sums are spent to hear out-and-out trash. These two sums total far more than that spent to hear music of high standard.

But this does not necessarily mean that this sort of music should dominate the radio.

Upon every broadcast director rests the responsibility of using for a constructive purpose this greatest musical opportunity that has ever been available to the public. These directors have no doubt had many unaccustomed problems to solve, and these difficulties must be taken into consideration when judging their programs. But they will never *rightly* solve the problem of radio music by appealing to the public to find out what is wanted. The majority of those who want good music will not trouble to express their desire. They will simply cease listening to the musical programs. Many of them have already done so because they think that very often the average musical program broadcasted is of a kind, both as regards the quality of the music and of the performers, that no one of discriminating taste can tolerate.

There must also be an elimination as to quantity, for there are not enough singers or players capable of giving public performances to justify even half the number of musical programs now sent out through the air. But that is another story.

The "Radio Trio" and Old Time Songs

FOLLOWING the comment made in this department last month regarding the grateful custom of some broadcast stations in featuring programs of old fashioned songs, comes the information that the first concert of this kind heard by radio was broadcast from station KDKA, Pittsburgh, the singers being Clara Huhn, soprano, Mabel King, contralto, and Roy Strayer, tenor.

These singers have been so in demand by



—Campbell Studios, New York

WILLEM MENGELBERG

For many weeks thousands of radio listeners heard the New York Philharmonic Orchestra every Wednesday evening give a program under the baton of the great Dutch conductor, Willem Mengelberg. With the closing of the Philharmonic's season came the end of what was one of the most remarkable musical opportunities ever afforded the radio public. The programs were broadcast from station WEAF

radio audiences that they are now known as, "The Radio Trio." But singing before the microphone is only an incident in their musical lives as they are all professionals occupying important choir positions and also filling out of town concert engagements.

Anne Griffiths, in whose studio these singers have received practically their entire training, is known throughout the Pittsburgh district as a musician of the highest ideals yet ever ready to seek new paths provided they give promise of leading to an artistic goal. This is why she was one of the first teachers of prominence in the country to encourage her artist pupils to broadcast. In response to the inquiry, "But don't they have to cheapen their work in order to be popular?" her reply was:

"Never! And let me add that the singer who must cheapen his or her art in order to please should not sing at all."

The popularity of this trio, as evidenced from the large number of letters received whenever they have broadcast, is indisputable proof that if you do a good thing well enough it will please both the connoisseur and the layman.

Roy Strayer, tenor



Mabel King, contralto



Clara Huhn, soprano



THE RADIO TRIO OF PITTSBURGH

Music Students before the Microphone

RETURNING to the subject of programs—commendation is due those broadcast directors who now and then present concerts given by the students of some well known school of music. Such programs offer a valuable opportunity to other music students in that they make possible a comparison of achievement that is often worth more than the stereotyped lesson.

A case in point was the concert given a short time ago by students at the Sherwood Music School of Chicago and broadcast through station KYW. It was an ambitious program consisting of numbers universally studied by advanced pupils, and in its execution was sufficiently good to be enjoyable apart from its special interest. Those students in other localities who heard it had a good chance to judge of the standard of instruction given in one of the largest music centers in the world.

And speaking of Chicago, since the *Tribune* of that city has taken over the Zenith station (now WGN), that station is fairly eating the air. And its musical programs are improving. The other night, just as this station was tuned-in, there came the surprise of hearing the opening phrases of what was immediately recognized as Debussy's "The Maid with the Flaxen Hair." To be sure, the piano tone did

not have the desired warmth, but for all that it was a joy to hear this charming number. The pianist proved to be Miss Caroline Johnson. Congratulations, Miss Johnson, for giving radio listeners a chance to hear this ingratiating number by the French composer who was the first great musical impressionist!

Debussy leads us to comment on the programs received from the Compagnie Française de Radiophone, of Paris. They recently featured a concert called, "Festival Erik Satie." What it must have sounded like via radio it is impossible to imagine. For Erik Satie is a leader among those Moderns who cast aside all musical rules and go their own wild and erratic way when they compose. Key signatures, the division of the music into bars, time signatures, these and all other rules mean nothing to him. And as for harmony, he evolves his own. Yet fundamentally Satie is a sound musician. But to hear him by radio would very likely cause more amazement than pleasure.

These French programs contain, in addition to works by native composers, others by the masters of German and Russian music. But, in the dozen or more programs at hand at this writing, America is represented only by, "Yes, We Have No Bananas," "Mr. Gallagher and Mr. Shean," "I Am Just a Little Blue," "I Want my Mammy," "Perfect Day," and "Swet Henry." Is "Swet" a misprint, or is

there a fox trot with such a title? One should never be ashamed to confess ignorance where knowledge should be bliss—hence this inquiry.

These numbers, compared with the remainder of the programs on which they appear, show all too clearly what the French think of American music.

The Funereal Star Spangled Banner

WHY broadcast "The Star Spangled Banner" at a tempo that makes it sound like a funeral hymn? Twice in one evening it came through the air at such a mournful pace one imagined that every flag in the country would be lowered at half mast in the belief that some terrible catastrophe had overtaken the nation.

In the name of all that is patriotic, speed it up, you who broadcast this national song!

EVERY announcer in the country might well follow the example set by the man at station WHAA, Iowa City, who spells the names of those heard during the program. We all know how difficult it is to understand perfectly a proper name the first time we hear it. Although speech sounds clearer over the radio—when you have the right kind of a receiving set properly adjusted—than it does otherwise, yet one cannot always be certain that the name is correctly heard. So we herewith present our thanks to that WHAA announcer who first speaks a name and then spells it. There was the case of the program of old hymns given at this station recently. They were sung with a simplicity so free from sentimentality that they sounded almost like folk songs. And the announcer made it perfectly clear that the singer's name was Jeanne Wolfe.

WLAG, the Twin City station, Minneapolis, has a woman announcer (and, indeed, executive director)—Miss Eleanor Poehler—who is the equal of any man announcer in the country and the superior of some.

And it was something of a surprise to hear recently a woman's voice announcing the number of an afternoon program broadcast from Ohio State University, Columbus.

After all, why not? Women have successfully competed with men in nearly every branch of work.—Why shouldn't they be not only announcers but also broadcast directors? Why shouldn't every large broadcast station have both a man and a woman director? Such an arrangement would contribute toward giving the programs a wider appeal. Men know some things about how to get satisfactory contacts with the public that women do not know; and by the same token, women know

some things regarding this same matter that men have never learned and probably never will.

This suggestion is offered to broadcast directors for contemplation, if indeed they ever have a chance in these hectic radio days to do any quiet detached thinking.

And Now—Programs in Spanish

IT WILL soon be quite the vogue to broadcast special programs given entirely in Spanish for the benefit of the Latin-American countries. The first complete program of this character was given at station KDKA by Mrs. Leora

Sage McKennan who, during her studies abroad, specialized in Spanish music, and by Victor Saudek and his Little Symphony orchestra. Mrs. McKennan sang a group of traditional Pyreneese songs and the orchestra numbers were either by Spanish composers or works based on Spanish themes but written by composers of other nations. The an-



—Nicholas Hay

WILLY POGANY

You could never guess his occupation from this picture, so we will enlighten you by explaining that he is a celebrated illustrator and decorator. He was born in Hungary, studied in Paris, spent ten years in London, and now lives in this country. He has illustrated more than one hundred books and decorated many famous buildings. He gave a broadcast talk at station WOR not long ago

nouncer on this occasion was D. Santini, of Santa Fe, Argentina.

Then, a few days later, station WGR at Buffalo gave a Spanish program in which all the performers, with the exception of the piano accompanist, were Spaniards. It was not necessary that the accompanist be of this nationality as the piano can speak in all languages with equal facility.

And now it's up to someone to write a song about, "Hands Across the Air."

Dramatic Celebrities —Alone

STATION WOR, L. Bamberger & Co., Newark, has been carrying a fine feature in the presentation of many dramatic celebrities in short talks or readings. This series, which has also included celebrities in other lines of endeavor, has been received with such enthusiasm as to prove beyond all doubt that people want something more than ephemeral entertainment over the radio. These talks have been instructive. And it seems the only desirable way for dramatic artists to broadcast.

It may be that the giving of plays by radio will sometime prove a practical method of producing drama, but at present, to some of us, it presents difficulties that make for dissatisfaction. WGY at Schenectady put on the comedy "Snowball," about a month ago, and although it came through clear, with every accent in speech plainly brought out, it all seemed fragmentary and confused. Like grand opera, drama appeals to more than the sense of hearing. It seems as if it were over-straining the resources of the radio to expect effective results when either opera or drama is broadcast. But perhaps time will bring out developments

along these lines that will astonish us. Indeed, nothing is impossible of execution of which the human mind can conceive.

WHEN station WOAW at Omaha celebrated its first anniversary in April, a portion of the program was given by members of the Chicago Bush Conservatory of Music faculty. The concert proved one of the best musical features heard via radio in many a day, and made some of those who listened to it lament that programs of this kind are not broadcast frequently.



ANNE GRIFFITHS

Whose achievements as voice teacher and coach in interpretation have done much to raise the standard of singing in Pittsburgh and vicinity. Miss Griffiths is a firm champion of the radio, and equally firm in her belief that it should be used to elevate musical taste rather than simply to entertain

THE monthly recital given by the Euterpean Club of Fort Worth through station WBAP is well worth listening to, not only because of the excellent performances given but also because they afford opportunity to realize the local talent available in that progressive Southern city. But for that matter, all who are closely in touch with musical development in this country know that Texas is ever abreast of the times in this respect. There is not a concert artist

before the public to-day who does not jump at the chance to get Texas engagements. And it is also a field that yields golden harvests to grand opera companies.

COMMENT made in this department last month on the inspiring effect of hearing by radio the choir of St. Paul's Cathedral at Detroit, has brought the information that the organist and musical director of the cathedral is the widely known musician, Francis A. Mackay. It is again a pleasure to speak of the vitally artistic quality of the choir's singing under his guidance.



DON WALLACE

An amateur radio operator of Minneapolis at his station 9 ZT. He was recently awarded the prize cup offered annually by Secretary of Commerce Hoover for the best amateur radio station in the country

The March of Radio

Hoover on Broadcasting Control

THE furor started by the "monopoly control" cries of station WHN when the A. T. & T. suit against it was started naturally would call for some statement from those government officials responsible for issuing radio station licenses. Perusal of the license law may not at once disclose clauses under which the Secretary of Commerce could act, to revoke licenses "for cause," but judging by the way in which Congress can act when it thinks of losing the soldier vote, it would not take more than a day or two to enact any law which the radio public might demand, provided their demands were backed by as powerful an organization as the American Legion.

Evidently feeling that the action of the A.

T. & T. Company in starting suit to close unlicensed stations called for some action on his part Secretary Hoover made public the following statement:

I am in receipt of many requests for my views as to issues now before the Courts bearing on the control of radio broadcasting. While it is impossible for me to express any opinion on particular issues that are before the Courts or the Federal Trade Commission, I can state emphatically that it would be most unfortunate for the people of this country to whom broadcasting has become an important incident of life if its control should come into the hands of any single corporation, individual, or combination. It would be in principle the same as though the entire press of the country were so controlled. The effect would be identical whether this control arose under a patent monopoly or under any form of combina-

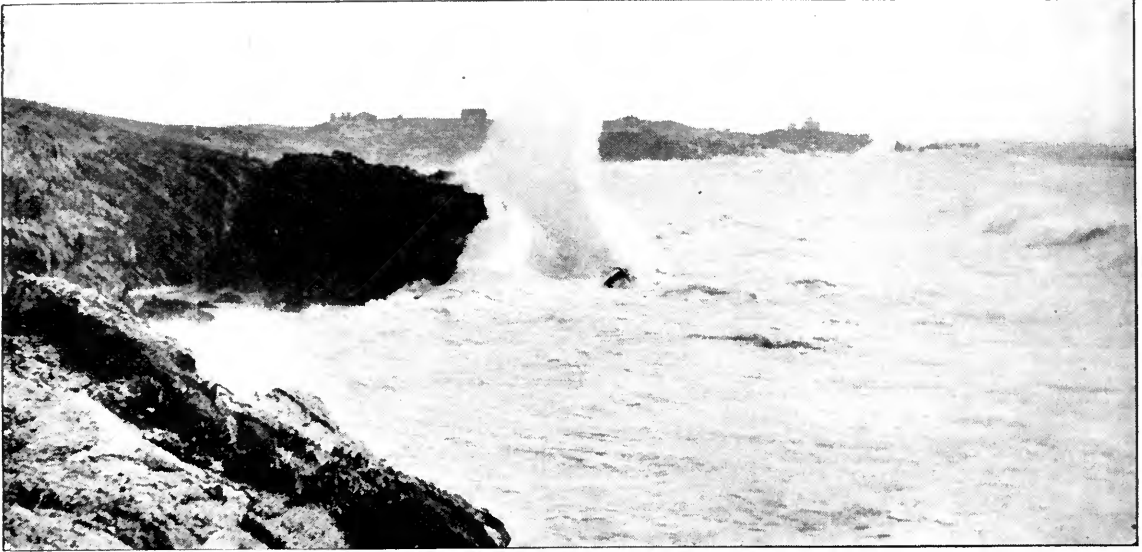

RUNNING ASHORE ON A COAST LIKE THIS

Is not to be relished, and it would happen more frequently were it not for the radio signals which supplement the warning flashes from the ever-vigilant outposts of our lighthouse service

tion, and from the standpoint of the people's interest the question of whether or not the broadcasting is for profit is immaterial. In the licensing system put in force by this Department, the life of broadcasting licenses is limited to three months so that no vested right can be obtained either in a wavelength or a license. I believe it is safe to say irrespective of claims under patent rights on apparatus that broadcasting will not cease and neither will our public policy allow it to become monopolized.

We heartily agree with the general sentiment of this statement. It is an excellent thing for United States radio that the department which grants broadcast licenses is supervised by such a secretary. We are not at all sure that the statement, "from the standpoint of the people's interest the question of whether or not the broadcasting is for profit is immaterial," is to be taken at its face value. Probably Mr. Hoover has not thought this thing through. We are not convinced that in this sentence the whole question as to how radio is to develop does not rest. "Radio for profit," the Secretary's statement notwithstanding, does not sound as though it promised much for the listener.

London Has Hard Work Getting Through to U. S.

WE HAVE yet to learn much about radio transmission. In the most recent attempt to bridge the Atlantic westward there were nine stations opera-

ting, all connected by wire to radiate the same program. Each of the stations was on a different wavelength. The power any one listener in America could pick up was that from one station only.

Although some elaborate preparations had been made to receive this transmission, very meager results were obtained. The RADIO BROADCAST super-heterodyne seems to have done as well as, if not better than, any other, but even this was successful in picking up music only; Marconi's message of greeting was apparently cast into a barren waste in so far as America was concerned.

It is Marconi's idea that this trans-oceanic transmission should be carried out by his ray radio, and we thoroughly agree with him. Could "mirror" stations be put up on both sides of the Atlantic there is no doubt that transmission would be altogether successful. What information we have on the method shows that if suitable mirrors were used at both transmitting and receiving stations the signal strength would be increased at least two hundred times.

When we think of KDKA's consistently successful 94 meter channel and WGY's recent transmission on 104 meters across the Atlantic it seems strange that the waves traveling in the opposite direction should encounter so formidable a barrier. We may discover why some day.

Squealing Sets to Go Surely

THERE is now no doubt that the single circuit regenerative receiver, against which RADIO BROADCAST has consistently waged war, is doomed to go. The dissatisfaction of the listening public has at last penetrated high places, and we now hear Mr. Sarnoff of the Radio Corporation tell a Congressional Committee that "the Radio Corporation recognized the problem of radiation and favored a law prohibiting the sale of receivers which produced audible interference with others in close proximity." Within a period of two years he would make it unlawful for any one to use a radiating receiver!

It is with great satisfaction that we see this company, many of whose sets constitute one of the greatest causes of interference, finally change its attitude on this question. It is, it seems likely, more satisfactory to us to think of this law prohibiting radiating receivers than it is to those hundreds of thousands who paid high prices to the Radio Corporation for the single circuit regenerative receivers which it so ardently advocated a short time back. It seems as though Mr. Sarnoff ought, in all fairness, to offer some sort of a reasonable "swap" with the former customers to whom he sold these sets, now condemned by him. It is hardly fair to sell a man something and then agitate for a law to make it illegal for him to use the apparatus.

Praiseworthy Broadcast Engineering

AT A recent dinner of the alumni of Massachusetts Institute of Technology, a feat of broadcasting was successfully accomplished. There was a notable list of speakers. The pick-up in the banquet hall operated

WJZ. From this operated WGY. KDKA intercepted WGY's transmission and started the program out again on two waves, one for its listeners and one to actuate its KFKX Hastings station as well as station 2 AC in Manchester, England. Hastings further relayed the program to KGO in San Francisco, which then threw it out over the West Coast and the Pacific Ocean.

As a result of this network control, cablegrams were received during the progress of the banquet so General Harbord, President of the Radio Corporation, was able to say that the speakers had been heard from Melbourne to Constantinople. Real broadcasting, which completely covers the civilized parts of the globe, is evidently not far distant.

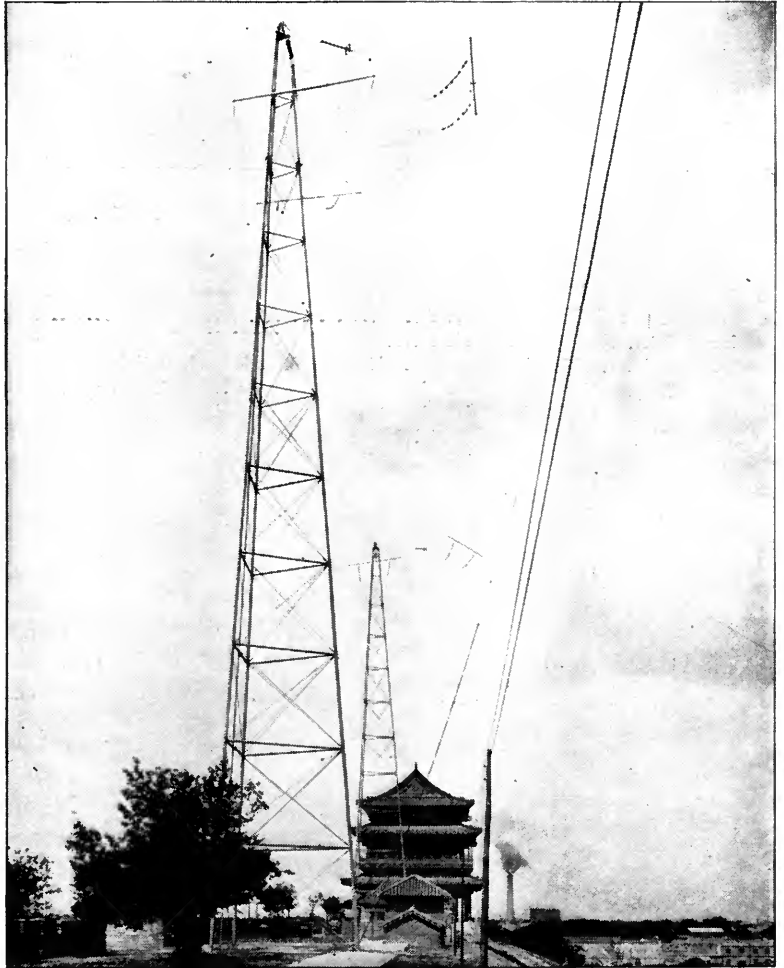

THE OLD AND THE NEW

The towers of the United States Naval radio station NPP at Peking show in decided contrast to the good old Chinese roof in the background

Outlaw Stations to be Closed

QUITE some time ago we were talking to an engineer of the American Telephone and Telegraph Company about the development of radio and the part his Company was playing in this development. At that time the Radio Corporation had been formed, and, as is now common knowledge, the Telephone Company had been given a virtual monopoly in selling transmitting equipment for broadcasting purposes. To offset this concession, the Telephone Company agreed to keep out of the radio receiver business. As a result of this agreement we have seen no A. T. & T. radio receivers on the market, although their well known amplifier unit to operate a loud speaker, convinces us that the Company certainly could design and build very excellent radio receivers. The

amplifier is evidently not construed in the Corporation agreement as "radio receiving equipment."

It seemed at once evident that the other members of the Corporation "put it over" on the A. T. & T. signatories. Greater profits are possible in the sale of millions of receivers which are used compared with those arising from the very few transmitting stations required to cover the country. Matters which seem so obvious are frequently not. Perhaps those responsible for the policies of the A. T. & T. Company looked farther than the immediately visible dollar of profit.

There is no doubt about the tremendous profits to be had from the sale of radio receivers — by merely glancing over the advertisements in any paper it is easy to see that any of the standard sets could be materially reduced in price and still leave a handsome profit for the manufacturer. In fact we predict this very thing will come about in the next few months. But of all the millions of receivers which the American people have bought and which have yielded many million dollars of profit to the Radio Corporation (other than the A. T. & T.) depend upon transmitting stations for their utility, and all the transmitting stations, according to the agreement, are to be furnished, and to a certain extent controlled by the Telephone Company.

There is apparently at least one objectionable clause in the contract which the purchaser of the transmitting set has to sign which compels the purchaser to agree not to use the station for profit, as WEAJ, the Telephone Company's own station is continually doing. For sending out the concert of The Happiness Boys or Chicklet Trio and whatnot, some firm is paying the Telephone Company about \$400.00 an hour. Naturally the managers of other stations would like to use theirs for a few hours each week in this fashion, but according to the contract they can't. There may be other conditions imposed upon the purchaser which seem to him unwarranted, but we hear more about this one than any other.



© Navana, London

HUGH S. POCOCK

Editor of the *Wireless World and Radio Review* of London. Mr. Pocock, in coöperation with the engineers of the British Broadcasting Company, had much to do with the success of the transatlantic broadcasting tests conducted last November by his magazine, the "B. B. C." and RADIO BROADCAST

The reader is very likely to conclude that in this matter the Telephone Company is monopolistically culpable, that it intends to keep a tight hand on any possible profit which may accrue from regular broadcasting. But the answer of our engineer friend to whom the question was put, shows that the gain of profit is at least not the only motive controlling the moves of the Telephone Company, if in fact it is the prime motive. Perhaps they feel that more profits may possibly be derived in an indirect rather than in a direct way. "The Telephone Company," said the engineer, "sees that radio broadcasting is very likely to develop into one of the most vital communication schemes of the age"—and his company is a communication company. The proper and reasonable development of the art, rather than any immediate profit, he thought, would be the force which decided the company's course.

He told of a case of a New York church asking for a broadcast set—the minister was badly infected with the "fundamentalist" germ and itched to spread his Sunday sermons beyond the walls of his edifice. Now to spread the teachings of Christ is surely the most noble task to which broadcasting can be put, but it is not at all evident that such would be the use of this set. So many preachers today insist on *their version* of what Christ taught. Views on the subject are so diversified that many times they seem almost opposed to one another. If this minister were allowed to broadcast, how about his "modernist" brother who professes Christianity as ardently? Shall he be refused a transmitting set, or shall the Telephone Company give him a set also and let the Sunday air be filled with conflicting ideas of Darwin and Bryan? And the conflict would be as bad in subject matter as in wavelength, since probably both would have to transmit at the same frequency.

Foreseeing this imminent battle of the ether if it sold a broadcasting set to any who apply, the A. T. & T. Company refused to sell a set to this church—with what result? The church is now operating a "bootleg set!" Dispensing the gospel over a channel which is operated against the laws of the United States—for the Government regulation, giving protection to a patentee, is as much a part of our Constitutional law as is that granting "life, liberty, and the pursuit of happiness." There are undoubtedly many broadcasting stations operating to-day in violation of law, for no matter



WILLIAM GIBBS McADOO

Addressing the radio audience before a Los Angeles microphone. Mr. McAdoo is another candidate for the Presidency who says he intends to use radio in the campaign

what arrangement of apparatus is used, all of them must use an oscillating triode as their source of power. The patent covering the use of oscillating tubes is owned by the Radio Corporation.

What then is to be done to these stations which are operating in defiance of the patent law? Are they to be left alone, or shall the patent law be enforced? The A. T. & T. Company proceeding legally against infringers, requested the Court to compel one of these outlaw stations, WHN, to cease operation or comply with the agreements under which the Telephone Company permits the use of its patents. This WHN settled out of court, acknowledging the validity of the patents and signing a license agreement.

This suit has started much loose talk about "freedom of the ether," "monopoly of broadcasting," but the public should not be misled by any such statements. The question at issue is a very simple one. Is the owner of a patent entitled to legal protection? If it appears that this question of broadcasting is so revolutionary in its service and requirements that the present patent law can be enforced only at the expense of the interests of the people then undoubtedly our patent law requires revision. But until that revision is enacted into law we can see no other solution to the broadcasting problem than compliance with the agreements the Telephone Company sees fit to incorporate in its licenses.

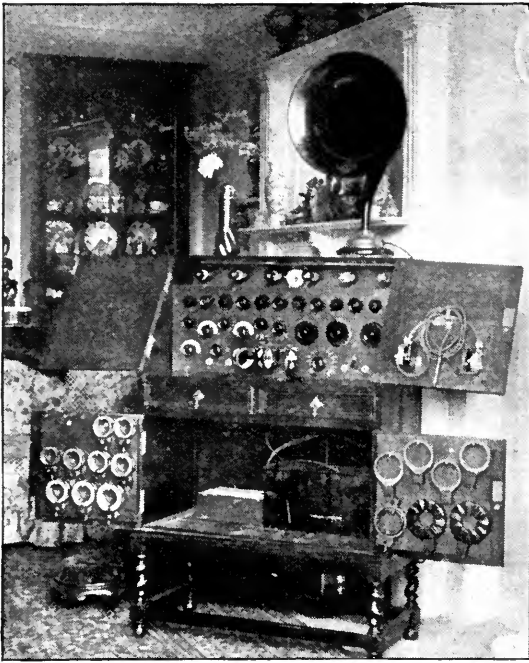

Courtesy Wireless World and Radio Review

AN ELABORATE BRITISH AMATEUR RECEIVER

Which is fairly characteristic of present day English amateur construction

It is probably fortunate for the broadcast listener that this question is at present in the hands of the A. T. & T. Company. This gigantic corporation with its hundreds of thousands of stockholders is subject to all kinds of governmental inquiry because of its interstate character. And if there is anything this corporation does not want to start it is a popular demand for government ownership of the American telephone system. Such a movement might gain considerable momentum under guidance of the radicals of North Dakota, for example, if it could be reinforced by the talk of "controlling the religious, educational, entertainment, and political destinies of the nation" which the management of station WHN asserted to be the aim of the Telephone Company.

We feel that some revision of the patent law is probably required; as it stands the people of the country give the patentee the opportunity to fleece them as much as he desires. If it is a cure for tuberculosis that the inventor discovers, he could legally collect hundreds of millions of dollars from the sufferers. Perhaps a patent on a device or idea which fills a great public need should have such extra governmental control exercised to insure to the people (who themselves grant the patent) of its rea-

sonable use. But the fact that WHN, by signing the agreement with the A. T. & T. Company, is not allowed to do advertising for money, cannot well be classed as an oppressive measure, as the manager of WHN seems to regard it. We think that the interests of the radio public are being conserved when such stations are prohibited from broadcasting for direct monetary profit. Direct advertising by radio is highly questionable even when tried by so excellent a station as WEAFL.

**A Municipal Broadcasting Station for
New York City**

VOLUMINOUS correspondence from Commissioner Grover A. Whalen of New York, has arrived. He mourns the difficulties he has had in trying to establish a municipal broadcasting station for his city. As he is apparently entirely dissatisfied with the manner in which the Western Electric Company is willing to sell and install its broadcasting apparatus, he has written at length on the subject, asking the Federal Trade Commission to investigate the "monopoly of the air" which he asserts the A. T. & T. Co. is maintaining. He explains the reasons for his actions in this matter in the last sentence of his letter to the Board of Aldermen—"I believe that the people of the City of New York, with its millions of radio fans, should be acquainted with the commercial aims and monopolistic tendencies of this Company to coerce the City which is endeavoring by means of the establishment of this broadcasting station to give maximum service and greater happiness to its citizens."

At the request of the city, the A. T. & T. engineers had estimated the cost of this station. It was due to their preliminary tests that the location proposed by the city (on the top of the Municipal Building) was found to be a very unsatisfactory one, and that another, much more efficient electrically, was found. This new location, however, seemed to be very poor, from the city's standpoint, because it required a wire connection with the City Hall and these wires would be owned by the Telephone Company. Altogether it seems to the Commissioner that this company is maliciously hindering the city's radio venture so he loudly calls for Federal vengeance.

The real facts of the case are not all brought out in the Commissioner's correspondence, but

he has apparently disturbed the Radio Corporation officials sufficiently to have them instruct the Westinghouse Co. to offer a broadcasting set to the city. Mr. Whalen is rejoiced that now he may broadcast without objectionable controlling agreements. Just how the city is going to use the set after it is obtained is not clear, neither is it apparent, we desire to point out to the Commissioner, that the stuff which is likely to be sent out from his station will "give greater happiness to the citizens" as he fondly hopes. If he would take the trouble to inquire, he would find out that most of his "million fans" are pretty well satisfied with the programs the other stations of the Metropolitan area have been furnishing them for the last year. He will have to extend himself a good deal to make the average citizen feel that the municipal station is not a nuisance, if it interferes in any way with these other stations.

The tone of the city administration's criticism of WEAF's managers is well shown by the stand taken on the acquirement by this station of permission to carry on experimental work of development during the hours from 2 A. M. to 2 P. M. In getting from Secretary Hoover this special Class D station privilege, he "finds this doministic (whatever that word may mean) company securing the one remaining concession that was needed in order to completely dominate and control the air. This appeared in the form of an order from the Secretary of Commerce notifying broadcasters that after this date there would be in existence Class D. or Broadcast Improvement Class, stations. So evidently this "doministic" company has hoodwinked Secretary Hoover and he too, is "agin the city."

Annual Report of the Radio Corporation

THE immense growth in the country's radio is indicated by the report of the Radio Corporation for the year just past. From a gross income of about \$15,000,000 in 1922, the busi-

ness of the company increased to more than \$26,000,000 in 1923. The net income of the Corporation has grown in a manner which should be very satisfying to the stockholders. It was \$426,799 in 1921, \$2,974,579 in 1922, and \$4,737,774 in 1923. Practically all of the increase in business resulted from the sale of receiving sets, many of them now to be outlawed, thus making way for others. Of the net income of the company only 9.5 per cent. increase occurred in transoceanic telegraphy and 17 per cent. in the marine traffic of the company.

Current assets of the corporation exceed the liabilities by more than eight million dollars and the 7 per cent. dividend on the preferred stock has been made cumulative. Two additional radio channels have been put into operation dur-



MUNICIPAL BUILDING

New York, where the City of New York is soon to install a 1000 watt broadcasting station. The old City Hall in the foreground

ing the past year, one to Italy and one to Poland. New circuits to South America are planned, in addition to which there are at present nine channels in service, to Great Britain, Norway, Germany, France, Italy, Poland, Hawaii, and Japan.

The report concludes with the statement that the company's engineers are devoting themselves to the solution of the broadcasting situation "with the ambition of perfecting the service to the satisfaction and benefit of the American people."

Armstrong to the Front Again

ON MORE than one occasion the radio receiver has received tremendous impetus from the contributions of E. H. Armstrong, the patentee of regeneration, super-regeneration, and the super-heterodyne. Now he has designed a new set which the Radio Corporation is selling under the name of the Regenoflex.

Seldom has it occurred in any field that one experimenter has contributed so richly. The regenerative receiver, with its ultra-sensitivity in the hands of a skilled operator, did more than any one other thing in the decade 1910-1920 to advance the art of radio communication. By

it European signals were consistently copied in the laboratory at Columbia University, using one triode. Ten years ago in the same laboratory it was generally possible to hear the West Coast stations talking to Honolulu (by code, of course) and to copy these messages when the stations themselves were continually calling for repeats.

His next contribution, the super-heterodyne, makes possible a most remarkable receiving set. This principle offers apparently the best method of getting high amplification of weak radio signals, and we have always recommended it as the best receiver, for those who could afford it. Its control is fairly simple, it is non-radiating, and it can be made to bring in the most distant stations, apparently still desirable to many broadcast listeners.

For his super-regenerator we cannot say so much. When properly built and adjusted this set produces a lot of noise, but that apparently is about what it is good for. As usually employed this super-regenerator amplifying arrangement gives very poor quality reproduction. Quality, is the one feature which the radio receiver manufacturer must strive for more and more. Radio transmission, *per se*, permits of almost perfect reproduction of voice and music, whatever distortion occurs is due to the



AT WHN

Billy West and Billy Murray broadcasting. WEAF's suit against this station for alleged violation of American Telegraph and Telephone vacuum tube patents was recently adjusted out of court

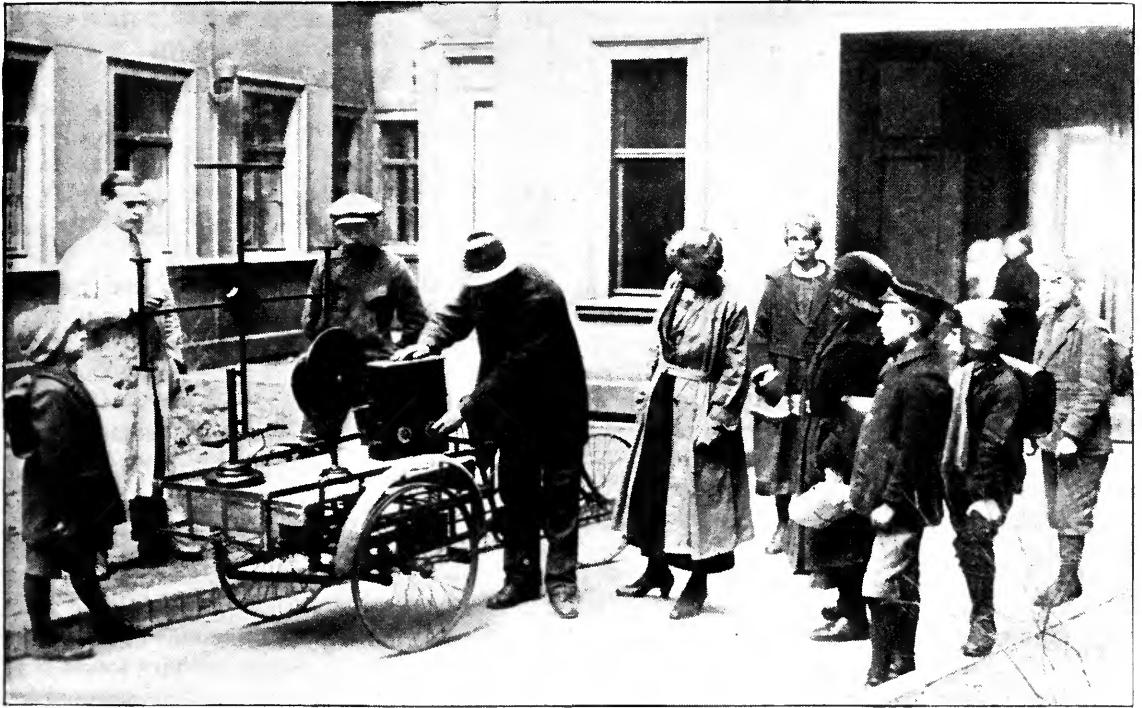

A MODERN ONE-MAN GERMAN BAND

Has been evolved by this rather ingenious German who has mounted this radio set on a cart, which may have before held his hand organ. He tunes in Berlin programs and depends on the financial appreciation of his audiences for support

imperfect electrical apparatus employed at the transmitting and receiving stations and the super-regenerator did not contribute much to the solution of this problem.

He has lately been endeavoring to make the operation of the super-heterodyne more simple and has apparently succeeded—at the same time lessening the number of tubes required from eight to six. He is of the opinion that his latest arrangement, in which regeneration and reflexing are employed, as well as the double detection idea, gives as good results (in so far as amplification is concerned) with its six tubes as is obtained with the ordinary circuit using eight tubes. The internal capacity of the triodes, between the grid and plate, is partly compensated as is done in the Hazeltine neutrodyne sets.

To make the adjustment of the local oscillator more independent of the loop antenna tuning, a “second harmonic” oscillator is used; the oscillator, instead of generating a frequency nearly the same as the incoming frequency, generates about one half this frequency and the intermediate frequency, for the intermediate frequency amplifier, is obtained by the beat note between the signal frequency and the second harmonic of the local oscillator.

The engineers of the Radio Corporation have done an excellent piece of design and construction on the new set, and if it is anywhere near as good in performance as the inventor claims for it, the Regenoflex should prove to be a popular receiver—provided the price is kept as low as the amount of material used in the set justifies.

J. H. M.

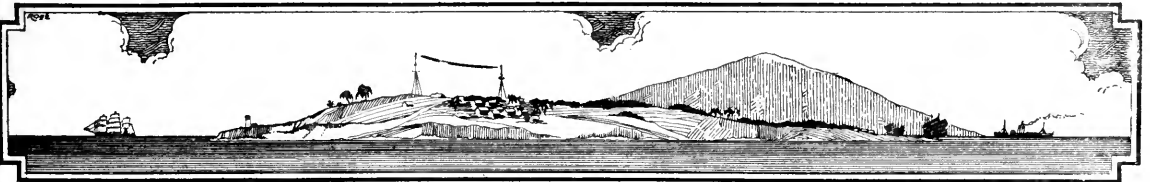

Pity the Poor Broadcaster

An Intimate Confession, Wrung from One of Them

By CARL DREHER

Drawings by F. F. STRATFORD

HOW fortunate you are to be in such an interesting business as broadcasting!" A professional broadcaster is doubtfully blessed by being forced to hear this remark, or something very similar, at least twice a day.

Well, it is not the worst business in the world, by any means. At the same time it has its drawbacks. Being in a gloomy mood, I purpose to enumerate a few of them.

The wonder and mystery of broadcasting have been so much cried abroad in the land that many people expect miracles of the poor broadcasters. For example, the matter of the placing of microphones. Everybody wants to be broadcast, but the microphones must not be visible, oh dear no. Hide them in the footlights, or hang them as high as Haman in the proscenium arch, or keep them warm behind the boilers in the engine room, but don't let any of the soloists, or speakers, or even the audience, suspect that there is a microphone in the house. If they do, all is lost, including honor. "What," I can hear them say, "the microphones have to be placed in certain definite places?" A long argument usually ensues, the broadcasting station's representative explaining that a microphone picks up only what comes to it in the form of sound energy, and that the operators, far from being able to make it behave otherwise, are different from other people only in knowing what the microphone will do and what it will not do. Thus, if it is placed on the floor under the piano, the piano will sound on the air like the merry bouncing of ash cans on urban sidewalks, and the rest of the show will be conspicuous by its absence, and the station will receive fifty-six hundred threatening letters the next morning from irate listeners, including the friends and families of the performers. Finally an agreement is almost always reached, for the representatives of the artists discover that the microphone is merely a round black object considerably smaller than a man's hand, on a slim stand, and that the broadcasters want to

place it only about waist high, and not, as was feared, right in front of the prima donna's nose. But in some cases, when it develops that the microphone must be somewhere, and there is no way of making it invisible like the air, all bets are called off, and the radio audience has to listen to something else.

IN THE STUDIO IT'S NOT SO BAD

ALL this applies only to outside broadcasting. In the studio, of course, the operators have things more their own way. But even in the studio, in the matter of placing bands, for example, it is sometimes found that the musicians balk at the positions selected for them. We must then compromise so that a fairly good orchestral balance can be had on the air with the musicians lined up so that they can play together. Usually this is accomplished by getting the different pieces to play with special loudness or softness, the music sounding better on the air, very likely, than in the studio. But it requires considerable persistence and tact to explain this to people.

Some performers are microphone-shy. This is often the result of exposure to a squawking loud-speaker overloaded to about ten times its proper capacity; hearing the result the listener resolves, rationally enough, never to let himself be broadcast. The worst of it is that the higher a man's musical competence, the more severe will be the case of micro-phobia be, and the greater the loss to the broadcasting art during its duration. The broadcasters who try to do uniformly good work, and succeed almost all the time, have to carry the handicap of poor broadcasting by other stations, and incompetent amateur and professional receiver demonstrations. The prejudices thus engendered injure the art as a whole, and the good stations suffer with the bad. Possibly it was after hearing the braying of some radio store's horn, trying to make enough noise to get over street traffic, that M. Clemenceau, on his recent visit to the United States, flung a

public address microphone to the floor on one occasion. It makes little difference whether or not the report is true. One can hardly blame his feeling.

TRYING TO MOVE AN AMBASSADOR

SOME listeners have an exaggerated idea of the power and influence of the technical staff of a broadcasting station. Recently, while WJZ was broadcasting the retiring British Ambassador, Sir Auckland Geddes, speaking at the Pilgrims' Society dinner from the Hotel Plaza in New York City, an irate listener called up the station to complain that the ambassador was talking too slowly, and was there no way to speed him up? On being told that ambassadors were in the habit of talking as fast or as slowly as they pleased, he hung up with a loud "Bah!" and is no doubt now going around telling the populace what dubs those broadcast fellows are, that not one of them had the nerve to step up to Sir Auckland and say "Hey, Ambassador, speed it up a little, wontcher?"

Every broadcasting station of any size is bombarded with requests from people who want to be mentioned on the air. Usually they are holding a party in honor of someone, and they explain that it would be so nice to turn on the radio and hear it tell the world that this is Mr. Ignatz Verplatz's birthday, and that they are giving a party in honor of the same at his residence on President Street, Brooklyn. This is, of course, a matter of intense public interest.

WHY READ TELEGRAMS?

THE larger stations, as a matter of fact, are discontinuing the practice of reading or acknowledging telegrams via the air. This was perhaps justified in the early days of the art, when it was a subject for great amazement that a certain station had been heard in Oshkosh, 400 miles away; but now this is such

an everyday occurrence that no further novelty or interest attaches to it. The stations are glad to get word from their listeners, of course, but the proper way to acknowledge them is by letter. The ether, it is becoming more and more evident, should be reserved for public entertainment.

Occasionally people send in technical queries, accompanied by hook-ups, and want them answered on the air. Just how this is to be done is not clear; at least until radio television or telephotography becomes a reality; talking about wiring diagrams, without a pencil and paper handy, is too much like lecturing on the fourth dimension. It is bad practice, in general, to send technical inquiries to a broadcasting station. The broadcasting engineers and operators have to worry about keeping the station on the air, and meggering wire lines, and doctoring microphones, and maintaining good quality, and it is hardly fair to ask them to diagnose the ills of individual receiving sets, when there are several radio periodicals with facilities for this service and willingness to extend these facilities to their readers.



"THEN THE PIANO SOUNDS LIKE THE MERRY BOUNCING OF ASHCANS ON URBAN SIDEWALKS"



“SOME PERFORMERS ARE MICROPHONE-SHY”

Keeping advertising off the air is another extra responsibility in operating a non-toll broadcasting station. Most of the performers understand the necessity for this and cooperate in good faith. Occasionally an attempt is made to put something over. One instance is on record where a singer of popular song hits started working in the name of a dance hall. He was promptly taken off the air—unknown to him, it is interesting to observe—for the balance of the number. Constant vigilance, and the exercise of quick judgment, are prime necessities in the operation of a broadcasting station.

SIMON SAYS YES, BUT SIMEON—NO

A BROADCASTING transmitter, like all mundane objects, has to be located somewhere, but, judging by the complaints of some of its patrons, one would not take this to be the case. The listeners who happen to be close by complain of the intensity of the signals, and request that the power be cut to one fourth, to make it easier to tune out the signals. Listeners at more remote points want louder signals, and urge that the station be made four times as powerful. It is very hard to please everyone, and broadcasting is pre-eminently a business in which one must try to please everyone. This brings up the question of dead spots in urban broadcasting. Every city station has areas, sometimes quite close by, where its signal is weak. There is sure to be a constant deluge of complaints from listeners in these neighborhoods who want to know why the other station, with no more power, and perhaps farther away, is louder. There are neighborhoods in New York City where signals

from one or more of the local stations are below the intensity of WGY at Schenectady or KDKA at Pittsburgh or WDAP at Chicago. It is hard to explain to people that this is an act of God, that the city was laid out or grew up naturally and more or less aimlessly, and certainly without any thought of broadcasting, and that the combination of man-made structures and the topography of the region, put together, make the transmission what it is in any particular locality.

THE BROADCASTING STATION:
BLAME HEADQUARTERS

THE broadcasting interests, like other public utilities, are blamed for a great many things for which they are in no wise responsible, as well as for their actual shortcomings. Besides dead spots, they are blamed for everything from high tension induction to static. When anything is wrong with the reception, most of the listeners can be trusted to be fairly discriminating and to put the responsibility where it belongs, but a minority can be trusted equally to make a scapegoat of the broadcasting station. Of course the staff of a broadcasting station is composed of human beings; they are willing to be condemned for their sins of omission and commission, but they do not relish being castigated indiscriminately. In the nature of their situation all their errors become public as soon as they are made—not a very enviable position at best. They may broadcast beautifully for weeks, and nothing is thought of it, but let there be a two-minute difficulty, and a few score of listeners who never thought of giving them a word of praise, let fly with both fists.

Radio has one other drawback; now that it has become a public plaything, one can never drop it. One's best girl insists on discussing the causes of blasting in loud speakers, one's brother-in-law wants to know how to get some tubes at a discount, the superintendent's set, which is out of order, has to be fixed before he can be persuaded to send up a little heat, the very bus boys and bootblacks inquire what is the best set to buy, how much it will cost, and whether it will receive Mars every night. Popularity has its disadvantages. A high official of one of the great corporations in the

field, leaving on his vacation for parts unknown, remarked gloomily:

"No one's been told where I'm going, and I don't know a soul there. I'm going to tell everybody I'm a plumber, so they won't talk to me about radio."

There are few radio men who would not

sympathize with this sentiment—at times. At bottom all of them including the writer of this jeremiad, like the business, "business," observe, not "game,"—for none of them is observed leaving it. Like newspaper work, it is fast, eventful, and fascinating. So we leave plumbing to the plumbers, who don't seem to mind.

A Correction

WE REPRODUCE in Fig. 1 the Kauffman circuit as originally published, by Mr. Kauffman, in a recent issue of *The Radio Globe*, the Saturday radio supplement of what was then the *New York Evening Globe*. We regret that this circuit was incorrectly drawn in the trick circuit article, which appeared in the March RADIO BROADCAST.

The principal electrical difference between Fig. 2 and the circuit first published, is the failure to indicate the inductive relation between the plate and grid coils—which, however, was described in the text of "The Truth About Trick Circuits." The interested reader will find it worth while comparing the circuit in Fig. 2 with the original text.

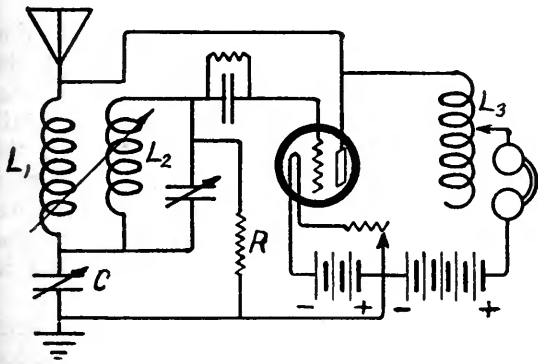

FIG. 1

The diagram, Fig. 6 in "The Truth About Trick Circuits" in RADIO BROADCAST for March. This was published as the Kauffman circuit. See Fig. 2

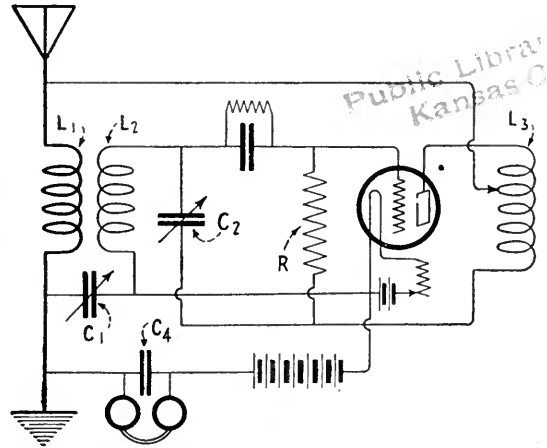
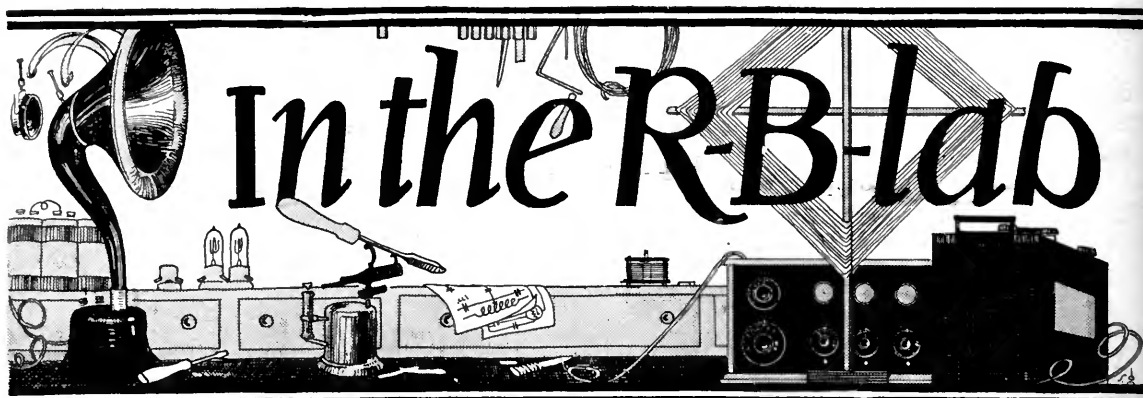

FIG. 2

The corrected Kauffman circuit

WHAT the English listener hears, what he has to hear it with, how much it costs, and some remarks about the radio climate are in W. H. Cary's "England's Venture into Broadcasting" which will appear in July.



The "lab" department has been inaugurated by RADIO BROADCAST in order that its readers may benefit from the many experiments which are necessarily carried on by the makers of this magazine in their endeavor to publish only "fact articles" backed by their personal observations.

THE TWO-ELECTRODE VALVE AND REFLEX SETS

THE two-element vacuum tube (a filament and plate), as a rectifier of alternating current, has been known for many years. Its rectifying properties were probably first noted by Edison several decades back whereupon its action was named the "Edison effect." Later, this principle was applied to the detection of radio signals by Fleming, in England, his tube being known as the Fleming Valve. This "valve" now finds its largest commercial application in storage battery chargers such as the Tungar and Rectigon.

In the triumph of the DeForest audion, which followed the introduction of the third element or grid, the Fleming valve practically

disappeared from the field of radio detection when it had barely developed beyond the laboratory stage. However, when the crystal detector became popular in reflex and certain other radio-frequency amplified circuits, the two-element bulb again suggested itself as a detecting possibility. It is more sensitive and stable than the crystal, and possesses the same admirable rectifying qualities which result in absolute purity of tone.

There are several commercial two-element valves on the market, and they may be added to any crystal rectified set by substituting for the mineral as shown in Fig. 1. The leads A and B should be reversed in order to determine the correct directional flow of current.

Though an extra A battery is indicated in Fig. 1, it will often be possible to utilize the same battery that lights the amplifying tubes—but this may require some experimenting. In using the common A battery, our tests have shown that the best results are secured by means of an unusual series filament connection, (Fig. 2). The filament of the two-element bulb is placed in series with the negative filament lead to the regular amplifying tubes. A 30-ohm rheostat is placed in shunt with the valve to regulate the current passing through it. Operated in this manner, the extra bulb is lighted *entirely without additional cost*. The energy which ordinarily would be dissipated and wasted in heating the rheostat, now lights the extra filament.

The remaining rectifying connections must

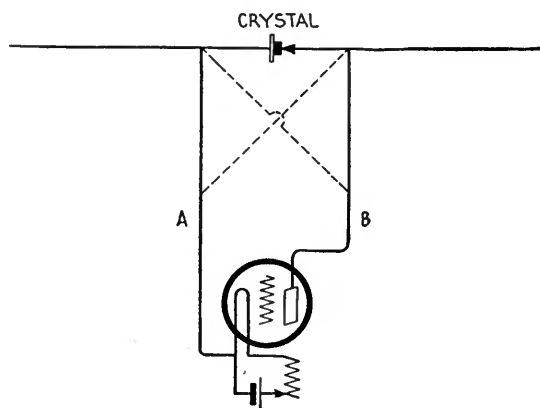

FIG. 1

The principle which may be followed in substituting a two element valve for the crystal detector in any circuit

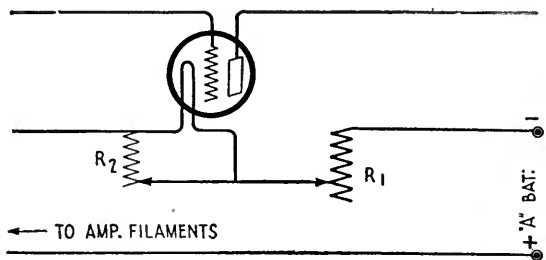

FIG. 2

The series filament connection recommended by the R. B. Lab. R₁ is the regular filament rheostat. Connected in this manner, the extra rectifying tube is operated with absolutely no additional expense

be "doped out" by the operators of individual sets, by following out the principle suggested in Fig. 1, and by noting the manner in which this laboratory has effected the change in the famous one-tube reflex circuit.

THE TWO-ELEMENT VALVE—AND THE KNOCK-OUT REFLEX

IN THE first place, the use of the commercial types of two-element valves is not practical in the case of single tube reflex sets. It is not possible to take advantage of the big jump in efficiency by the "free" lighting of the additional filament. The commercial diodes consume in the neighborhood of $\frac{1}{2}$ ampere, while the tubes used in these sets draw $\frac{1}{4}$ ampere or less.

It is obvious that to operate most efficiently (the best result at the lowest possible cost), the one-tube reflex with a two-element bulb rectifier, the rectifier must be of the same amperage as the main tube, and of a lower voltage, so that it may be lighted in series with the main tube—using up the spare voltage difference that exists between the battery voltage and the operating voltage of the tube. The operating voltage of the UV-201-A is $4\frac{1}{2}$, and, when a six volt storage battery is used to light the filament, $1\frac{1}{2}$ volts are left over, generally to be wasted in the rheostat.

Even though commercial two-element valves, meeting these requirements, are not to be had, the matter is easily solved by making your own rectifying tubes, with the correct amperage to order.

"MAKING" YOUR OWN TWO-ELEMENT TUBE

IT IS only necessary to procure a standard three element tube of the required voltage and amperage. The plate and grid are connected together, and this common connection is used as the plate terminal of the rectifier. The result is a rectifying tube that our experiments have shown to be superior to the usual commercial two-element valve.

If the UV-201-A, or the C-301-A, operated from a six volt battery, is the main tube in the single bulb reflex (which, incidently, is the best possible arrangement, for voltages up to a hundred and twenty may be used without distortion), the rectifier tube may be a WD-11 or -12, or a Western Electric "N" tube (Fig. 3), with the plate and grid bridged as we have directed. The connections for this ultra efficient arrangement are indicated in Fig. 4.

The use of the WD tubes and the UV-199, as a main-tube-rectifier combination is not so practical due to filament complications. How-

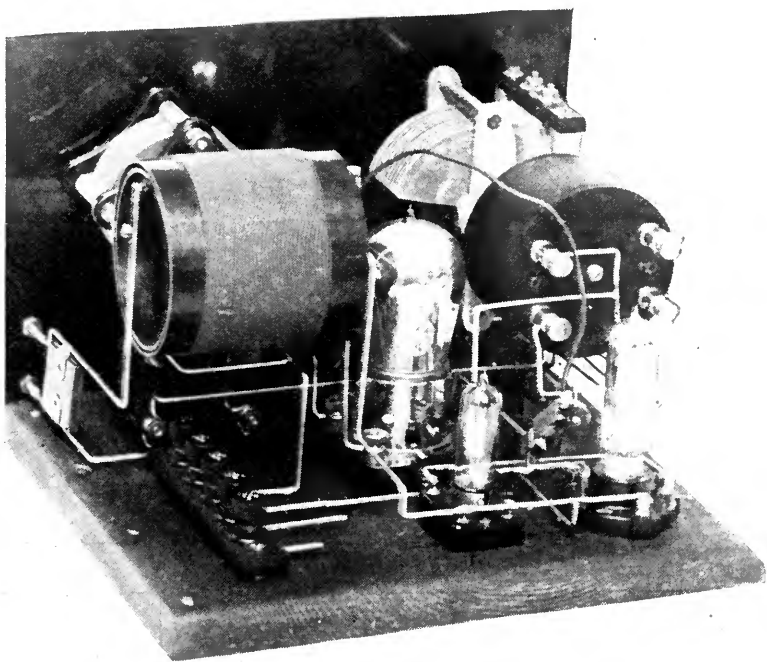

FIG. 3

Back view of the R. B. test set. Comparing a commercial two element valve with a Western Electric "N" tube and crystal. Note the two unused binding posts. This being a test set, room was provided for expansion

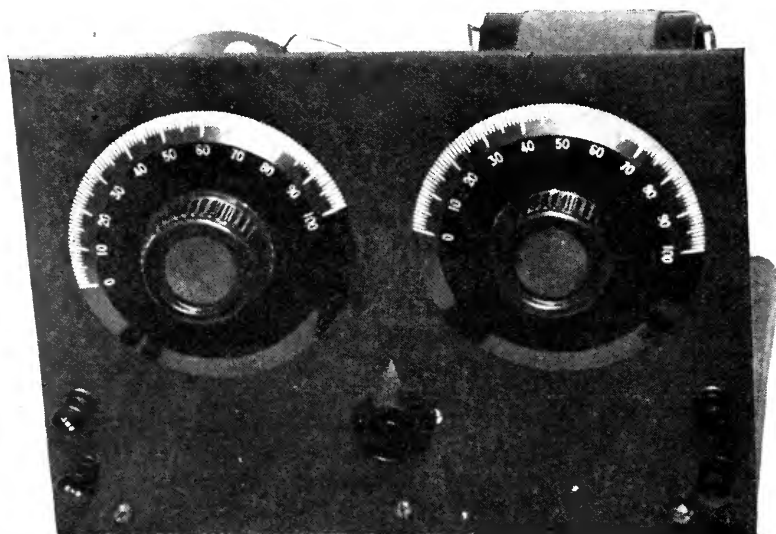

FIG. 5

A front view of our experimental set. A very neat layout, using a seven by ten standard panel. Antenna and ground binding posts are on the left, with output posts on the right

connection also applies to the use of the commercial two-element valve such as the "Diode." (Employ our connections rather than those suggested in the circular accompanying that tube.)

If identical tubes are employed, for instance a WD-12 for main tube and another, with plate and grid bridged, for rectifying, the *series filament connection* is still used, but the A battery voltage is doubled.

The best possible combination is that first mentioned, i.e., the UV-201-A as the main tube, and a $1\frac{1}{2}$ -volt, $\frac{1}{4}$ -ampere tube as the rectifier, the series filament being lighted from a

ever, if the possession of these tubes makes this combination particularly convenient, the UV-199 should be used as the main tube, and the WD-11 or -12 as the rectifier, with an extra dry cell connected as shown by the dotted line in Fig. 4. *Be sure to follow the indicated polarities.* The two A batteries are "bucking" each other (positive to positive), but are connected purposely in this manner. This extra battery

single six volt battery.

Care must be observed to follow the initialed connections to the audio-frequency amplifying transformer, T₃.

A marked improvement in selectivity, due to increased functioning on the part of T₂, is noticed when using tube rectification. The circuit is also more stable, and the telephone shunt condenser, C₃, a .002 mfd. Micadon,

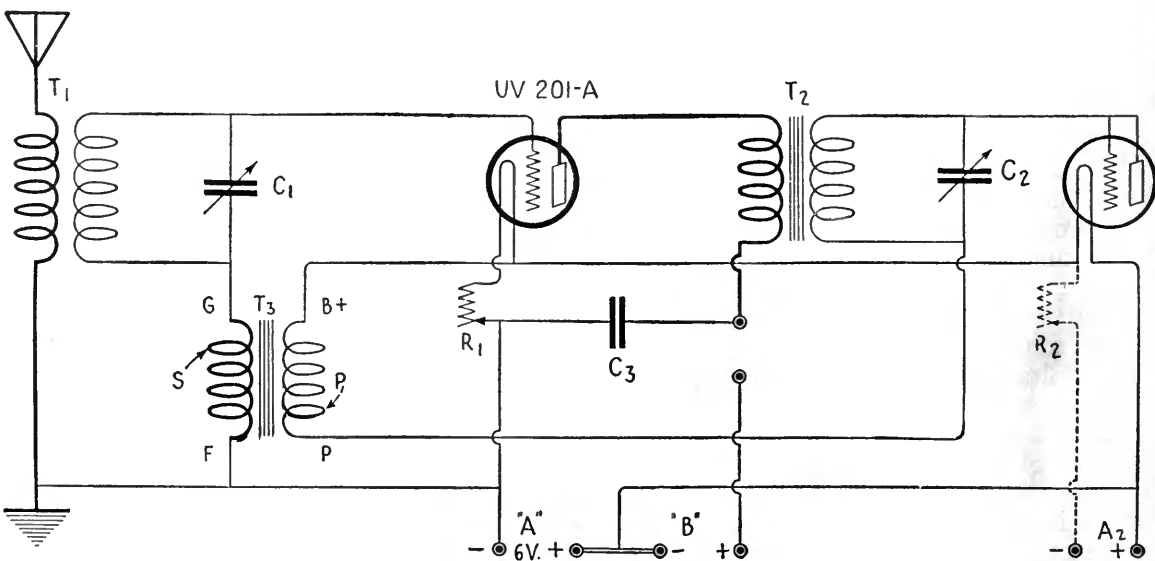

FIG. 4

The circuit of our one-tube reflex plus two element valve detection, a more selective and sensitive set than the former "Knock-Out" set with a crystal detector. The extra filament costs nothing to operate

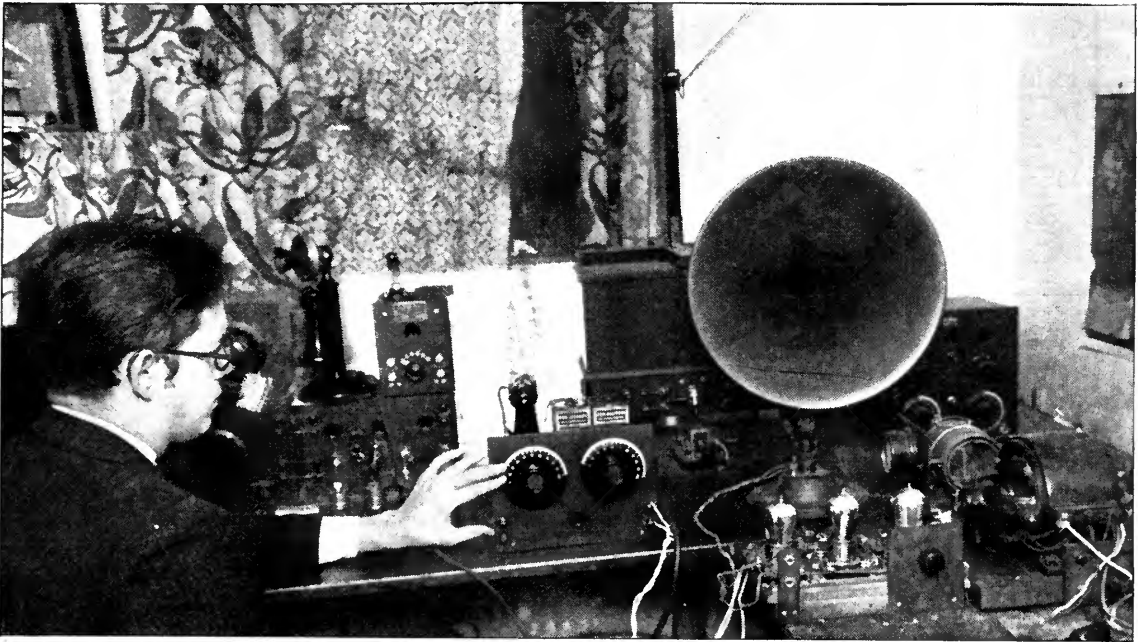

FIG. 6

Testing the two element valve arrangement, plus a three stage resistance-coupled audio amplifier—the ideal combination. Incidentally, a partial view of radio station 2 PI

may be used with beneficial results, without inclining the circuit toward oscillation.

COMMERCIAL INDUCTANCES AND THE ONE-TUBE REFLEX

THE windings T₁ and T₂ of diagram Fig. 4 may be those described in the One Tube Knock-Out Reflex article appearing in the April RADIO BROADCAST, or may be two of several types of commercial inductances now on the market. These latter will appeal to enthusiasts who, for various reasons, do not care to wind their own coils.

T₁ (right, in Fig. 3) is an enclosed inductance made by the Ray-Dee-Artcraft Instrument Company, Redlands, California, known as a "Tuned R. F. Reflex Transformer." T₂ is a standard neutroformer type coil, purchased from the Teale Supply Company, New York City, with the primary rewound. While we have found that the boxed inductance used as T₁ is best suited as the antenna coupler, neutroformer type coils, with rewound primaries, may be employed both as T₁ and T₂. The primaries should be rewound (assuming an approximate winding diameter of 2 $\frac{3}{8}$ inches) with 15 and 35 turns respectively T₁ and T₂.

Due to the small space provided for primary winding on the Workrite neutroformer, the primary of T₂ is best wound over the outside of the secondary.

Figs. 3, 5 and 6 show various views of the set on which the tests described in this article were made. A clip, shown in Fig. 3, was used in changing quickly from crystal to diode detector.

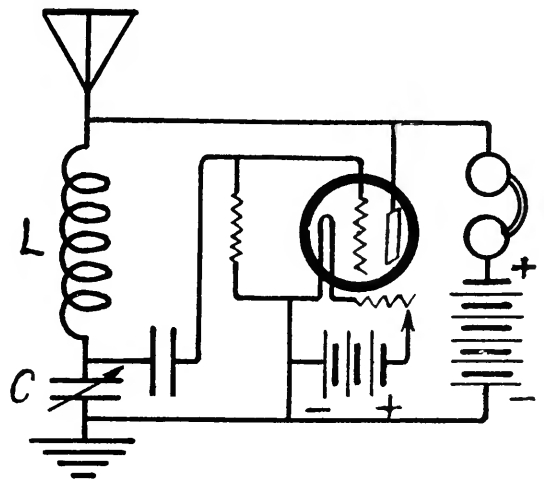

FIG. 7

The Colpitts Oscillator, which can be changed to a very efficient circuit by adding the Reflexit

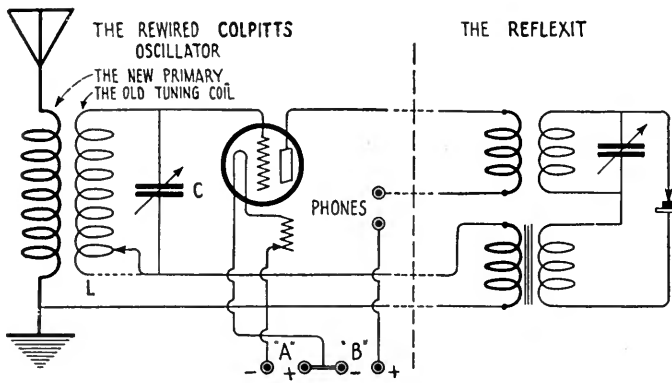

FIG. 8

The complete circuit—the re-wired blooper plus the Reflexit. This is a real receiver

THE REFLEXIT AND THE COLPITTS OSCILLATOR

IN THE early days of broadcasting, before the evil possibilities of radiating receivers were appreciated, the Colpitts oscillator became very popular as a receiving circuit. Particularly recommended to home builders by its simplicity, it being probably the most easily constructed of all receivers, it was widely described under a hundred different names, and built by a hundred thousand enthusiasts. This circuit (which is actually a transmitting system, and designed as such) is shown in Fig. 7, and some of the names under which it has insinuated itself into an all too general use are, "The Simplex," "The Peterson Automatic Regenerative," "The Flivver," etc. A fuller description of its characteristics and evils will be found in "The Truth About Trick Circuits," appearing in the March RADIO BROADCAST.

This circuit, which has been exiled by all considerate enthusiasts and dealers, can be reclaimed from the ash-can by the use of the Reflexit, described in this magazine last month. By making a few changes in the Colpitts circuit, and adding the Reflexit, this radiating receiver is transformed into a single tube reflex set—a real DX receiver, of marvelous quality, signal strength, and superior selectivity.

The May RADIO BROADCAST contains detailed instructions on how to make the Reflexit, and adapt it to the tickler feedback single-circuit blooper. It may be added to the Colpitts Oscillator with equal simplicity.

REWIRING A COLPITTS SET

THE first thing to be done is to disconnect all instruments in the set—leaving the receiver as if it had never been wired. In the Colpitts Oscillator, Fig. 7, L is generally a coil of wire, wound with one hundred turns on a three inch form, and tapped, perhaps, every ten turns. Sometimes L is an untapped coil of about sixty turns of wire, tuning being accomplished by varying the capacity of condenser, C. In either case, a layer of paper is placed over this coil, L, and a primary of twelve turns is wound with about No. 22 wire, over the paper. If a two and a half inch tube was originally used as the winding form, wind the primary with fifteen turns of wire; if a three and a half inch form, wind ten turns.

It now remains only to rewire the set according to the diagram, Fig. 8. If L is an untapped coil, it is connected across the condenser (the former capacity feedback variable) as shown by the dotted line. The instruments to the left of the vertical dotted line represent those salvaged from the old single-circuit blooper. Flexible leads, in the rear, connect the reflexit with the rebuilt tuner.

The Reflexit combinations will work best

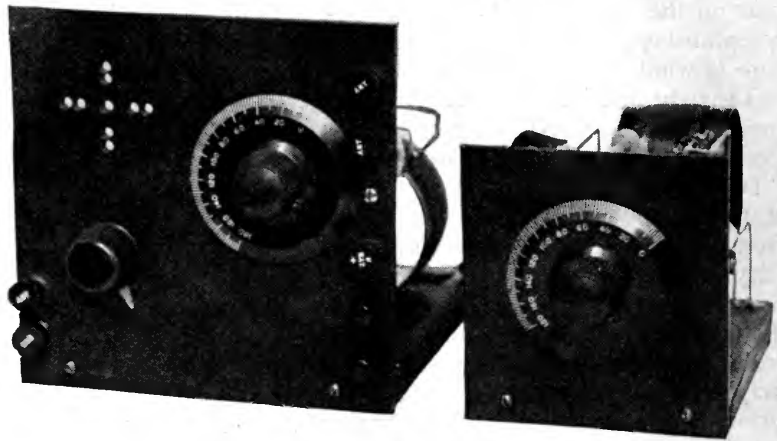

FIG. 9

The new set. The Reflexit is on the right

with the UV-199, C-299, UV-201-A and the C-301-A tubes.

Figs. 9 and 10 show front and rear views of the completed combination, which is the famous single-tube reflex circuit. The apparatus photographed and described possesses remarkable selectivity and volume, far exceeding those qualities in the original single circuit receiver. In our laboratory, it brought in all local stations on the loudspeaker (with real intensity) and not merely permitted excellent selectivity among WEAf, WJZ, WJY, and WHN (all locals), transmitting at the same time, but brought in KDKA on phones, through the local bedlam.

BUILDING YOUR OWN LAB

THE gasoline torch is a laboratory essential, and this month, it is our suggested addition to the growing laboratory. A small torch will cost between three and five dollars. Do not compromise with quality, but purchase a reliable torch, paying a higher price for it if necessary. Nothing but the very best should go into the equipment of the radio laboratory. It is cheaper in the long run, and safer all the way around.

Fig. 11 shows a torch of the most convenient size. It is small, as compared with the hand holding it, and yet is capable of very heavy work. Its uses are many, but it will probably prove its genuine value on out-of-doors solder-

ing. Engineers have reiterated the necessity of soldered joints in the antenna and lead-in connections, which, however, are almost impossible to effect with a rapidly cooling iron, working on the unheated wire. The gasoline torch may be described as indispensable in the erection of an efficient antenna.

It also has many laboratory uses. The torch is generally fitted with an iron holder, for the heating of the ordinary soldering iron. This is particularly convenient for experimenters, whose shops are not equipped with electric soldering apparatus. The electric soldering iron, however, is much to be preferred wherever practicable.

The iron can only be used efficiently when soldering small objects. For soldering on wire of size lower than No. 8, B. & S., and on fire escapes, waterpipes, etc., the torch is absolutely necessary if a good joint is to be made.

USING THE TORCH

THE individual instructions of each manufacturer for the operation of his torch should be carefully observed and followed. When the basin is first lighted, the gasoline will

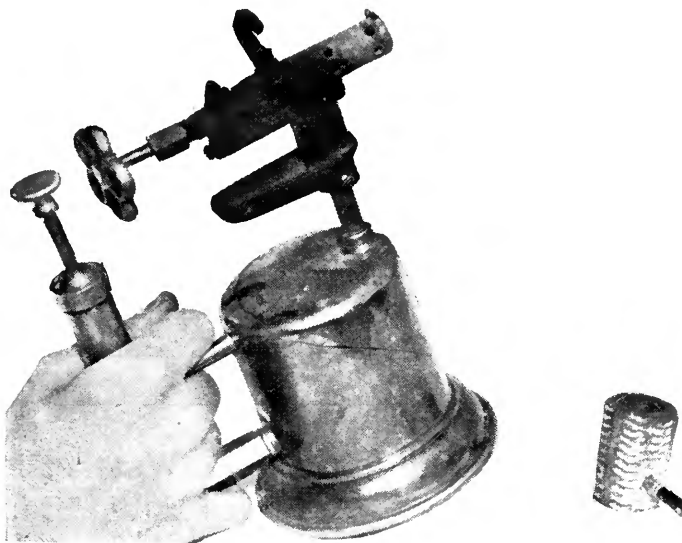

FIG. 11

A small torch, but one capable of quite heavy work

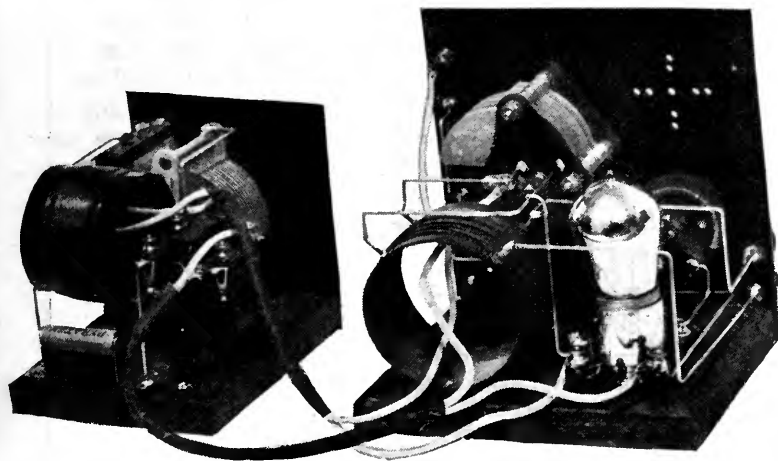

FIG. 10

The rear view of the Reflexit combination

probably have trickled down along the torch, to the floor, and for a moment there will be an alarming and general conflagration. However, count ten before you send in the fire alarm, and all will be well.

In soldering large and cold objects, the metal should be enveloped in the tip of the flame, and warmed until it will melt solder. The flame is then moved slightly to one side, or played upon it from a distance, so that the hot metal, and not the flame, melts the solder.

The flame should be used at full blast only on very cold or large objects.

An asthmatic or sputtering flame indicates that gasoline is low. A weak but constant flame means lack of pressure—a few swift pumps are necessary.

In operating the torch out-of-doors, the blast should be maintained considerably higher than in the laboratory, even on small work. This is to keep the needle valve from cooling in the cold air and wind.

Market Information and Weather Forecasts from Central States Radio Stations

U. S. Department of Agriculture, Weather Bureau.

Program for Broadcasting Weather Forecasts and Reports by Radio—Illinois Section

90th Meridian Standard Time
All are Radio Telephone Except Great Lakes

NAJ, Great Lakes: (telegraph) (151 Kilocycles) 9:15 A. M.—morning lake forecasts, aviation forecasts; 4:00 P. M.—special warnings; 9:30 P. M.—evening lake forecasts, aviation forecasts.

KYW, Chicago: (560 Kc.) 12:00 noon, (11:00 A. M. during local "Daylight Saving")—morning local forecast, state forecasts, lake forecast; special warnings at 2:15 and 4:15 P. M.; 9:25 to 9:30 P. M.—evening local forecast, state forecasts, lake forecast. Monday, "silent night."

WAAF, Chicago: (1049 Kc.) 10:30 A. M.—morning local forecast, state forecasts, general forecast, general weather conditions, aviation forecasts, shippers' advices during winter season, national weather-crop summary and state summaries on Wednesday during crop season; 12:30 P. M.—repeats the 10:30 A. M. information, also weekly outlook issued on Saturday.

WDAP, Chicago: (833 Kc.) 10:00 A. M.—morning local forecast, state forecasts; 10:00 P. M. or later, at end of regular program—evening local forecast, state forecasts, lake forecasts, general forecast, general weather conditions. Monday, "silent night."

WOC, Davenport: (620 Kc.) 11:00 A. M.—morning local forecast, state forecasts, river forecast, general weather conditions, state weather-crop summaries on Wednesday; special cold wave warnings sent as flashes. Tuesday, "silent night."

WJAN, Peoria: (1170 Kc.) 9:15 A. M.—morning local forecast, state forecast, shippers' forecasts; repeated at 11:30 A. M.

WEW, St. Louis: (1150 Kc.) 10:00 A. M.—morning local forecast, state forecasts, general weather conditions, river forecasts; special warnings at 5:00 P. M.

KSD, St. Louis: (550 Kc.) 10:40 A. M.—morning local forecast, state forecasts, general weather conditions, river forecasts and stages; special warnings at 12:40 P. M., 1:40 P. M. and 3:00 P. M.; 10:00 P. M.—evening state forecasts.

Amateurs receiving weather forecasts are requested to advise (by mail) Weather Bureau Office, Springfield, Ill., of the quality of service received and how distinctly the stations are heard.

Adventures of a Wireless Free-Lance

A Thrill that Came Thrice in a Night-time

By GEORGE F. WORTS

WHAT tales they could tell—if wireless operators only dared! No wide-awake lad can hammer brass on the high seas for very long without collecting a fund of delicate information which he will refrain from putting into his memoirs. The oath of secrecy to which he solemnly swore when he obtained his license placed a seal upon his lips and an emergency brake upon his pen. If he confided his secrets to the public, his license might be revoked; he might be summoned to answer embarrassing questions in court; he might even spend some time manufacturing brooms or automobile license plates. He might, in any event, cause some one a great deal of trouble.

The traveling public has always looked upon the wireless man as a mystery man; and that attitude is the correct one for the traveling public to take. A wireless operator is, in a sense, a walking Pandora's box!

I know one operator, now on a Transpacific run, who dares not tell what he knows concerning a certain shipwreck in which several lives were lost because of another operator's negligence. The negligent operator went to a salty death proclaimed a hero. Further details in that case I cannot safely divulge.

The war came after my time, at sea, but I am sure that a great many of the wireless men who served during that adventurous period must fairly be bursting with secrets.

What goes on inside an operator's headphones is sacred. Wild horses could not drag from me some of the things I have plucked out of the air; but I do not believe I will be violating the spirit of my old oath in relating the story of the three distress signals that came my way in a single night. It happened a good many years ago; the actors in that far-flung drama are scattered now to the four quarters of the globe; no one, so far as I am aware, made any

mistakes; and, just to be on the safe side, I will refrain from mentioning the names of the ships which took part. Some facts I will disguise, but the conditions and sensations of that night I will reproduce as faithfully as I know how.

I was at that time the second operator on a large fast ship which we will call the *Saurian*, although any Pacific coast operator who chances to read this article will penetrate my secret in a jiffy.

The *Saurian* had the honorary title, in wireless circles, of "supervisor ship." She ran on a regular, close schedule between San

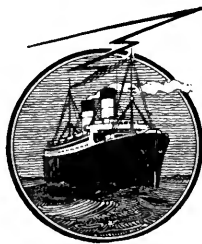

Francisco and Honolulu. Her wireless house was a square bump on the boat deck just abaft the funnel and it boasted a wireless installation probably very similar to the one with which Noah equipped the Ark. Judged by present standards it was, at all events, antique and quaint. The transmitting set comprised a two-kilowatt open core transformer of the United

Wireless type, a battery of Leyden jars mounted in a handsome imitation mahogany cabinet for a condenser, a helix of silver-plated copper tubing, and a rotary spark gap driven at about three thousand r. p. m. and producing, when received, a mellow melancholy note. It was the sweetest spark I ever heard. Our wavelength was somewhere in the neighborhood of 600 meters, although nobody knew and nobody cared. The set was a freak. It had a tremendous range. That antique transformer consumed, I am sure, more than forty amperes; and we had amazing radiation. Because of our phenomenal sending range and the express-train regularity of our schedule, the *Saurian* had become the Pacific supervisor ship. That is to say, we had the authority of a land station over other ships within range. We relayed an immense amount of traffic and were supposed to supervise the radio manners of our brethren. It goes without saying that the operators on the *Saurian* were keenly aware

of their importance, and heartily disliked by all.

On the run with which this chronicle is concerned, we pulled out of San Francisco on a nasty gray day in the teeth of a stiff head wind. Wind pressure ran up to fifty miles an hour before we were abreast of the Farallones; and two days later, as we plunged and wallowed westward, we ran head-first into a howling eighty-mile gale. All afternoon we plunged and pitched and corkscrewed. The first operator came off watch at midnight, limp and greenish of complexion, and I went on the job in a state of mind and stomach even more pronounced.

Everything that could come loose in the wireless cabin had already come loose. Spume was flying the length of the ship with the stinging force of hail. The full-gale howled in the funnel guys and aerial wires. The wireless cabin rose and fell with that swooping sensation peculiar to express elevators in forty-story buildings. We were five decks above the water line.

It was a bad night on the air as well. When I put on the phones and adjusted our carburetor detector, static came sputtering in. It was faint and distant but persistent enough to interfere with long distance work. KPH and KPJ, the San Francisco and San Pedro shore stations, were droning out storm warnings for the entire Pacific coast; but business proceeded as usual. I relayed a string from an incoming Jap boat to KPH and another batch from KPH to the *Sonoma*, a Union Liner in the Australian service, a day out of Honolulu, east-bound.

Then quiet, save for the static, descended for almost an hour. A copy of my log for that night, which I preserved for years, was destroyed recently in a fire, and I must rely upon a somewhat unreliable memory. Shortly before two o'clock everybody seemed to get busy at once. The Jap had another string for me to shoot along to KPH. KHK (Honolulu Marconi) wanted me to relay a batch to KPH—he couldn't work him direct because of the static—and ships all over the Pacific were buzzing away. As I recall it, from two to three o'clock in the morning was always the busiest hour of the night on the Pacific.

And through that busy buzzing I suddenly heard a far-away, whispery SOS—or believed I did. I immediately called Frisco and

asked him if he had heard an SOS. He replied that he had not, and told me to send a "CQ" which meant, in those days, "All stations stand by!" The list of international "Q abbreviations" had not then been adopted. But a CQ was not needed. Following my brief query to KPH and his answer, the air cleared magically.

THE NIGHT: THREE S O S CALLS

I STOOD by for orders from Frisco, and after a moment he told me that he still heard nothing. I knew he had not heard, for, long before he started to send, the faint, far-away, whispery spark was calling again. It was so faint that the shuddering of our ship obliterated it; so faint that it hardly reached me through the scratching of the static. Somehow I had always pictured a ship in distress as being conveniently near, and the faintness of this spark made me believe that the whole Pacific Ocean lay between us. For all practical purposes, it did.

While I was straining my ears to catch his call letters, a vigorous, clear, crisp buzz filled my 'phones.

"SOS—SOS—SOS—de—W—"

A second ship calling for help before I could even identify the first one! The next half hour was destined to be the busiest I had ever lived. Within that half-hour, there were three of them. The gale must have dropped down from the sky and struck the entire Pacific at a single blow.

If you will glance at a map of the Pacific Ocean and make a mark one third of the way from San Francisco to Honolulu on the course which ships on that route follow, you will know the approximate position of the *Saurian* on that terrible night.

"Can you hear either of them?" I snapped at Frisco.

"Don't hear anything but static!" Frisco snapped back.

In an interlude between splashes of static I caught the call letter that the far-away whispery spark was sending, and a glance at my list of calls identified it as a fishing boat. The second distress call had been despatched by a tramp freighter.

For a moment I didn't know what to do. Then I sent a general CQ; told the tramp to stand by and the fishing boat to report his position; and I will never forget the agonizing



faintness of that distant, husky, faltering spark.

It was necessary for him to repeat each word three times, and even this laborious procedure left blanks that I filled by guesswork. Repetition in transmission when you are in a hurry is always irritating, always nerve-wracking; and on that occasion, as I tried to read that whisper of a sound and to shelter it with cupped hands from the rumbling of the *Saurian*, the squeaking of the wireless room woodwork and the shouting of the wind, it was maddening.

"Have not seen the sun in days," he painfully pounded out, "and have been blown so far off our course we can only guess where we are. Captain says we are about Lat.—; Long.—"

The exact position figures I do not recall. It does not matter, for no one ever verified them. At all events, the distressed fishing boat was about seven hundred miles north of us. I asked him about his condition.

"We are in very bad shape," the faint whisper answered. "Forward cabin smashed in. All boats gone and only one raft left. Pumps can't keep up with water. Fireroom is flooding. We are lying to, with engine turning

asking for a report from any ship within running distance of the distressed fishing boat—and no one answered. For ten minutes I pounded away, trying to raise some one; and that was the beginning of the most real tragedy I have ever experienced. Perhaps my imagination cut the thing out of whole cloth, but, as I saw it, there was I, carrying on conversation with a man who might, in the next breath, be strangling to death in icy salt water; and the *Saurian*, apparently the nearest source of help, was two days at full sea speed away from him!

In answer to my further calls, presently a shrill whine was heard. It was a Nippon Yusen Kaisha boat, a Jap, on the Seattle-Yokohama-Hong-Kong run.

"Four hundred miles due south of him. Advise," said the Jap.

"Keep in touch with him and try to raise some ship nearer to him," I answered.

And it was then that the third SOS of that packed half-hour came droning in—this time an oil tanker. The operator gave me his position without having to be asked for it.

"Away off our course, but estimate Lat.—; Long.—"

NOTICE

DEPARTMENT OF COMMERCE
BUREAU OF NAVIGATION
RADIO SERVICE

SECURITY OF MESSAGES—FALSE SIGNALS

The act of Congress to regulate radio communication, approved August 13, 1912, provides in the nineteenth regulation and in the seventh section, respectively, as follows:

Nineteenth. No person or persons engaged in or having knowledge of the operation of any station or stations, shall divulge or publish the contents of any messages transmitted or received by such station, except to the person or persons to whom the same may be directed, or their authorized agent, or to another station employed to forward such message to its destination, unless legally required so to do by the court of competent jurisdiction or other competent authority. Any person guilty of divulging or publishing any message, except as herein provided, shall, on conviction thereof, be punishable by a fine of not more than two hundred and fifty dollars or imprisonment for a period of not exceeding three months, or both fine and imprisonment, in the discretion of the court.

SEC. 7. That a person, company, or corporation within the jurisdiction of the United States shall not knowingly utter or transmit, or cause to be uttered or transmitted, any false or fraudulent distress signal or call or false or fraudulent signal, call, or other radiogram of any kind. The penalty for so uttering or transmitting a false or fraudulent distress signal or call shall be a fine of not more than two thousand five hundred dollars or imprisonment for not more than five years, or both, in the discretion of the court, for each and every such offense, and the penalty for so uttering or transmitting, or causing to be uttered or transmitted, any other false or fraudulent signal, call, or other radiogram shall be a fine of not more than one thousand dollars or imprisonment for not more than two years, or both, in the discretion of the court, for each and every such offense.

(TO BE POSTED IN RADIO STATIONS)

A FACSIMILE OF THE ORDER OF SECRECY

Which is displayed in every radio operating cabin

only enough to head us into it. Old man wants to know how soon you can get help to us. We won't hold together many hours."

TRAGEDY—700 MILES AWAY

IMAGINE having that responsibility placed personally on your shoulders by a man seven hundred miles away! I sent out a query

I reached up and made another mark on our chart of the Pacific. The oil tanker was approximately five hundred miles away, in a southeast by south direction.

"KPH," I called, "can you hear W—?"

"Can't hear anything but static," Frisco replied. "Handle them all."

I called for a condition report from the tanker.

"Rudder is jammed," was the answer. "On our beam ends in the trough. Danger acute. SOS—SOS! Must have help at once!"

Then:

"SOS!—SOS!—SOS!" buzzed the tramp "Sinking! Send help!"

The shrill whine of the Jap stopped and I could hear the fishing boat's despairing whisper:

"SOS!—SOS!—SOS! Somebody—please—answer!"

It was dreadful! I desperately told the fishing boat to continue calling; the oil tankers to shut up and stand by; the tramp to give me position and condition.

He gave his position, and I made another mark on our chart of the Pacific. He was approximately twelve hundred miles northwest by west of Cape San Lucas, which is the lowermost extremity of the peninsula of Lower California, or about six hundred miles southwest of the *Saurian*.

"Wave stove in hatch-cover in forward deckwell hour ago. Hold flooding. Bow almost submerged. Waves breaking all over us. All boats smashed or lost. Must have help quick."

I asked if any ship was near him. There was a prompt answer from a Pacific Mail passenger boat in the San Francisco-Panama express service.

"Am about forty miles southeast of him. Any one any nearer?"

It appeared that no one was nearer. I instructed the Mail boat to deal with him; then went to work on the oil tanker. I sent out the usual query, asking any ship near him to answer. There were three replies. The nearest ship was a Blue Funnel, a British freighter, between fifty and sixty miles northwest of him. I told the Blue Funnel and the oil tanker to work it out between them.

You may be wondering why the *Saurian* acted in a supervisory capacity in the handling of those three distress calls; and the reason is interesting. I do not believe that three distress calls received simultaneously under exactly those conditions would be handled in that fashion to-day. They would be handled individually and simultaneously by the ships nearest the distressed vessels. In those days, tuning-out interference was much more difficult than it is to-day, for three reasons. To-day,

the transmitting sets of all ships are much more sharply tuned; a variety of transmitting wavelengths is available; and receiving apparatus is much more selective. If I had not supervised all transmission very rigidly that night, no one could have worked through the jam. We were all working on six hundred meters, and our waves were very broad.

Now, all of this may sound cool and orderly, but permit me to state that there was nothing cool or orderly about the state that my mind was in. The crisis had turned me into an automatic nervous machine. I was so panicky that I had to grip the key firmly with the fingers of my right hand and hold my right elbow steady with my left hand. Nor was the state of my nerves eased by the plunging, the pitching and the corkscrewing of the *Saurian*, the squeaking of the woodwork, or the howl of wind and hiss of spray. My chair was lugged down to the floor, and my legs were wrapped tightly about the chair-legs or I would have been catapulted out of it.

HOW THEORY DIFFERS FROM COLD FACT

AFTER the arrangements had been made for the relief of the oil tanker and the tramp I must have sat for fifteen minutes with both hands clamped over the phones, forcing them down on my ears, trying to collect my wits. I have often imagined other operators I have known—men who are calm and cool and resourceful—going through that ordeal with a steady hand and a steady eye, logging it all up as they went along, crisply reporting each event as it occurred to the officer on watch, as a well-trained operator should do. It would be pleasant to paint a picture of myself as that sort of hero. But I wasn't a hero in any respect; I was a quaking, terrified, blundering kid, forced by circumstance into a position of tremendous responsibility that I would have eagerly shirked. Later on, in my capacity of nine-day wonder, I assumed a lofty, nonchalant pose in static rooms; looked down upon ordinary operators with a great deal of disdain, and admitted under their bombardment of questions that the emergency had found me brave and composed; but the twenty or thirty operators who were listening in within range of the *Saurian* that night knew me for the monumental young liar that I was! I make my confession now without the slightest



embarrassment. But let us get on with the story.

The Blue Funnel reported that the captain had changed her course and was going to the rescue of the oil tanker. The Pacific Mail boat reported that she was steaming full speed to the aid of the crippled tramp. And the Nippon Yusen Kaisha reported that the fishing boat no longer responded to his calls.

The rest of the night the Jap and I devoted to trying to raise the fishing boat or any ship within short running distance. The operator of the fishing boat did not reply again. In those days some ships carried only one operator, whose duties were divided between working the radio and some other kind of ship's business. I had hoped that the operator of such a ship might listen in sometime during the night; but no one answered. We were probably still appealing for help long after the fishing boat broke into pieces.

The night was practically gone when my nerves really gave way. KPH called me and I tried to answer, but my hand would not work the key.

DID THE NIGHT SWALLOW GROPING MESSAGES?

EVERY nerve in it seemed dead—or disconnected. The thought of the fishing boat going down—that operator, with whom I had been talking, trying vainly to be of some help, probably a dead man by this time—made me limp and dizzy. I hated the sea as I have never hated it before or since. I made up my mind never to go to sea again. But I did, of course. You always do. And I hated static that night, too, more than I have ever hated it before or since. I have always thought that that man was trying to tell me something that the static would not let me hear. He kept on sending. The Jap, with his poor understanding of English, must have missed the sense of

it. Did he send some message that no one received—just before his ship went to pieces? That I might have missed such a message is one reason why I have told this story to very few people. . . .

Day was breaking when I went out on deck for a breath of fresh air. The force of the gale was broken, but mountainous waves were rolling down upon us from out of the misty grayness. Spray stung my face and spattered hissing on the hot funnel. It did not seem possible that a ship as large as the *Saurian* could roll and plunge so and not rip apart. Every moment she staggered and thundered as waves piled completely over the peak.

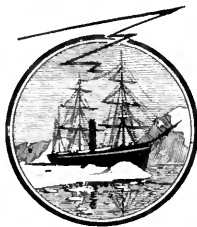

The second mate came aft, lurching from one permanent object to another. He gave me a glare as he approached. He was a grizzled old timer, a relic of sailing ship days—the kind of ship's officer who thinks that wireless operators are insulting reminders of a mechanical age that is taking more and more of the kingly authority out of the hands of the men who navigate ships. He stopped near me and bawled above the wind:

“Say! What in hell are you doing away from your post? Don't you know you belong in there with those things on your head? How do you know but what ships are in trouble all over the Pacific in weather like this?”

Well, that's the life of a wireless operator. Anyhow, it was in those days. Maybe times have changed.

The fishing boat was the only complete disaster of the night. Parts of her were found floating about the sea, but none of the crew was saved. The Blue Funnel towed the tanker back into Honolulu for repairs; and the Mail boat took the crew off the freighter. She was still floating when they got away, but went down before night.

READERS of this magazine are reminded that our \$500 Prize Contest on the best answer to the question “Who is to Pay for Broadcasting—and How?” closes on July 20th. A complete announcement of the terms of the contest appears on page 69 of RADIO BROADCAST for May.



A TRADING POST ON THE MACKENZIE RIVER

Probably one of the most northerly parts of the world where a radio receiving set is permanently installed. This place is just two hundred miles south of the Arctic Ocean. The black outcrops in the river are beds of tar sand

A Canadian Broadcasting Station

Interesting Bits About CJCA—a Pioneer Station in a Pioneer Country. How “Great-Spirit-in Box” Goes Along With the Trader’s Rifle, Pemmican, and Tea

By H. F. MULLETT

GRAY EAGLE, chief of the Yellowknife Indians who inhabit the Mackenzie basin district of the Northwest Territories, away up at the top of the map of the American continent, and a thousand and more miles north of Edmonton, the capital city of Alberta, swung his bale of raw furs from his dog-sled in front of the fur trader’s post, grunted an order to his squatting dogs, and entered the store.

“How!” he remarked, in answer to the Scots trader’s hearty greeting. “Bring furs! How much?”

With rapid appraisal borne of long experience, the trader skimmed through the valuable pile and named his figure.

“No good!” grunted Gray Eagle. “Price better! ask how St. Louis market from Great-Spirit-in-Box!”

And for two days, until the trader, in his lone post a thousand miles from any city, got the latest fur prices by radio from CJCA, the Edmonton *Journal’s* broadcasting station at Edmonton, Gray Eagle waited with true native immobility, nor would he part with a fur or a

pelt until he knew from “Great-Spirit-in-Box,” how the market was running.

That’s why it is safe to make the statement, that probably few broadcasting stations on the American continent serve a wider field, and for more diverse uses, than does CJCA. The station call letters daily reported by the *Journal* operator, G. A. R. Rice, whose sonorous announcement that “this is CJCA speaking—CJCA, Edmonton *Journal*, of Edmonton, Alberta, Canada, the sunniest spot in Sunny Alberta,” has been picked up away down at Key West, and, in fact, at many other distant places all over the United States.

From the Montana boundary to the Arctic circle, there are but two cities in Alberta where long distance broadcasting is done, and of these two cities, the work done by the Edmonton station is by far the most interesting, by virtue of the scope and diversity of its field. CJCA, of course, isn’t a station in the midst of a wilderness, for Edmonton is a city of 70,000 people, growing rapidly toward the 100,000 mark, with half a dozen lines of railway radiating from it, and with every modern convenience such as is enjoyed by dwellers in any large city in America.

PIONEER RADIO SERVICE FOR REAL PIONEERS

BUT because Edmonton is a big and growing city practically on the edge of civilization, its work with radio must necessarily be of a pioneer nature, and much of its service must be to a people still in the pioneer stages, hewing out farm homes from the virgin land, building railways into virgin territory, mapping, surveying, exploring, trading with native tribes, bending mighty rivers to its will, and ever pushing onward and outward even to the shores of the bleak Arctic itself.

The romance of the *Edmonton Journal's* broadcasting lies with that little army of pioneers out almost on the ragged edge of nowhere, to whom CJCA means the only link with civilization—a civilization reached only after months of arduous travel in many cases—a civilization from whence, at long intervals, men with mail bags struggle through to bring news that may be a year old before it reaches its destination.

But even the farm home, in this land of great distances, takes on its own touch of the romantic, for railroads are still all too few, and there are farms to-day, in Northern Alberta, fifty, sixty, a hundred, and more, miles from any railway. What CJCA means to these folks, leading the lonely life of pioneer settlers in a new land, can be realized only by those who have shared the lot of these pioneer people.

Out beyond the last thin steel line of railway that marks the edge of a civilization itself so new as to appear actually to the visitor uncivilized, goes each year that little band of trappers and explorers, government surveyors and missionaries, prospectors and traders, Mounted Police and fire rangers—to join that other little band already there—many of them with years of pioneer work to their credit—many asking nothing better than to live and die in the lone spaces of the Northwest.

And more and more, despite the fact that northern travel calls for limited equipment, the radio is being taken “down north” by these men of the frontier. Canoes may

be small and frail—portages long and hard—camps a hard day's journey in between—snow, ice, wind, rain, thaw, fire, and every danger the elements may command, may lie in wait at each turn of river or trail—but the “Great-Spirit-in-the-Box” goes along with the rifle, the pemmican, and the tea.

Down the broad bosom of the mighty Athabasca and Mackenzie rivers, when the spring ice has gone out, and all the land is astir with life of bird, and tree, and beast, go the government men, forever surveying, mapping, reporting—and the black box goes with them. Camp at night means CJCA, with its music program, its world news, and maybe, its personal message for some one of the party.

Its use in the fur trade has already been indicated. Two years ago when world prices in furs dropped heavily and suddenly, traders of the north were actually paying more

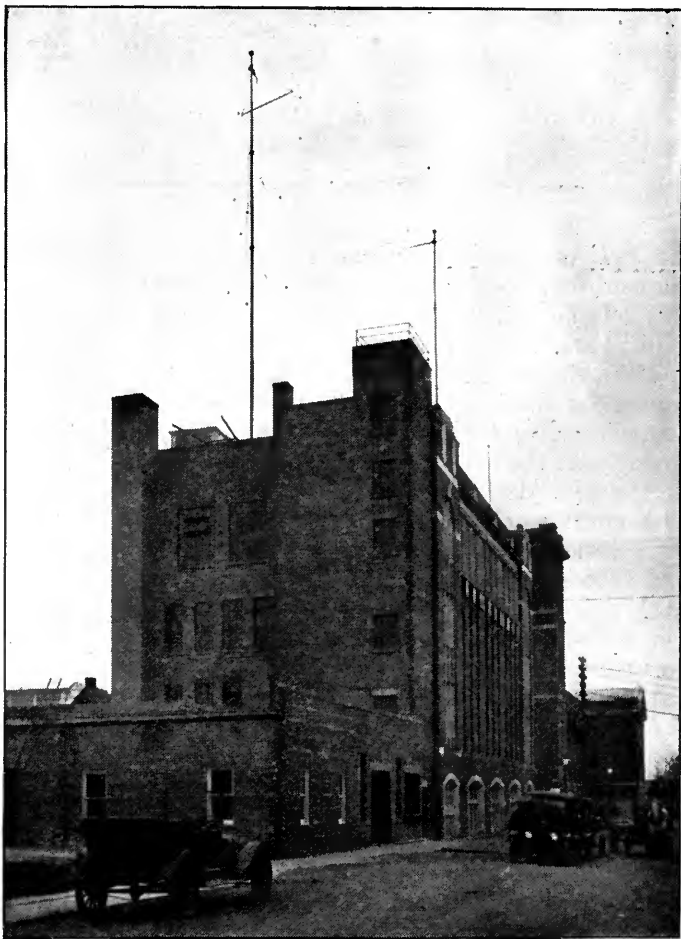

THE EDMONTON “JOURNAL”
—Newspaper and radio plant in far-off Alberta

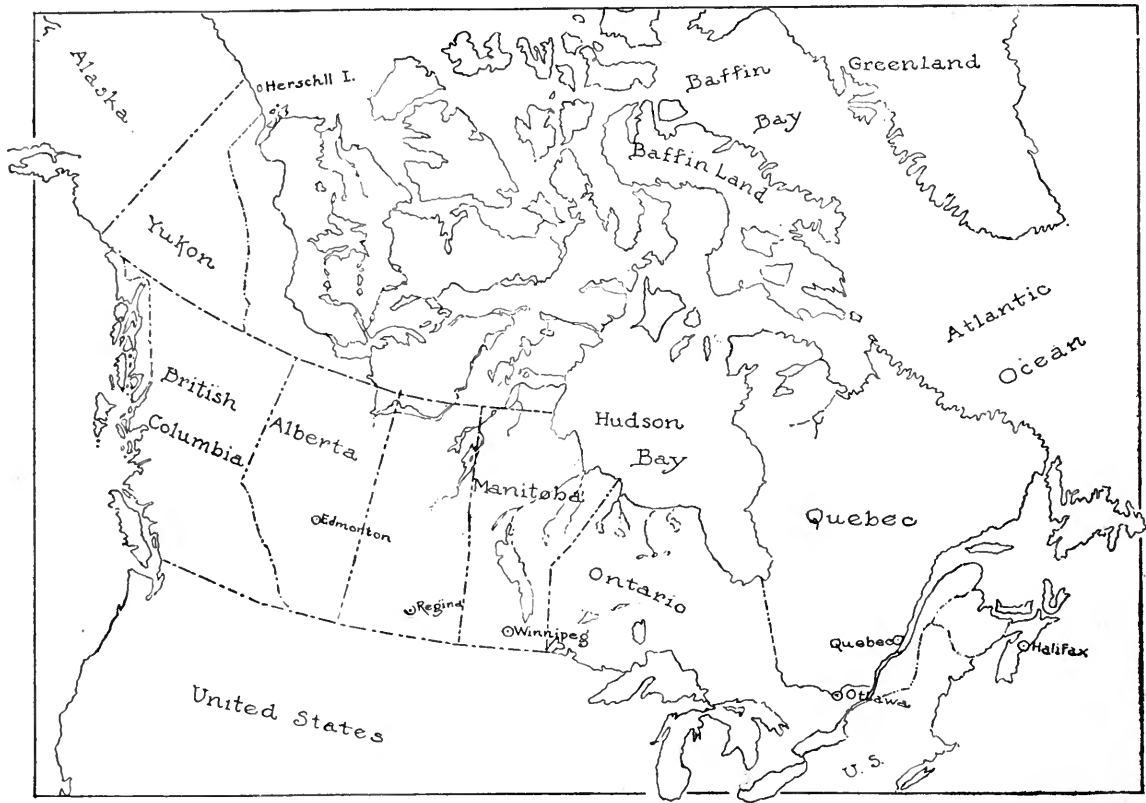

for raw furs from the Indian and Eskimo trapper, than New York, St. Louis, or Montreal was offering. The radio is solving this difficulty, and saving thousands of dollars.

Through thousands of miles of uncharted timber, as the hot sun of the short northern summer bakes the rotting vegetation dry as tinder, goes the fire ranger, pack on back, with his faithful dog as companion. He carries with him a small receiving set and each night after six he strings his wire to a convenient tree, and listens to his chief, away up the river at McMurray, sending out instructions, giving him the news of the country and of the world, and maybe ending up with a tune or two on the gramophone.

Already, the Canadian Government, recognizing the potential value of radio in the northland, has announced its intention of setting up a string of stations between Edmonton and the Arctic Ocean. One such station is already installed, and this year may see a government station even on Herschel Island, the Mounted Police headquarters for the Arctic.

Station CJCA has already done good service for the police, in sending out urgent messages

of wanted people, stolen autos, etc. The value of this work may be illustrated in the case of a foreigner, who was wanted for murder. The fugitive was thought to be heading south from Edmonton. CJCA broadcast his description, and in a few minutes a radio fan in Southern Alberta, twenty miles from the railway and the nearest police detachment, had picked up the message and had telephoned it to the police detachment.

GOOD DEEDS

IN Edmonton Hospital the wife of a commercial traveler lay awaiting a serious operation. Her husband was on his rounds, in small places where the ordinary means of finding him were useless. CJCA located the husband in a few hours, and he came into the city on a fast freight, in time to be at his wife's side during her time of trial.

Soon will Arctic loneliness—pioneer loneliness—the loneliness of the remote farm home and the distant trapper's cabin—be a thing of the past. Soon will Amokuk and his Eskimo friends, in their ice igloo on the Arctic shores, sooth and amuse their babies with radio stories

from CJCA's childrens' hour, and Yellowknife, Dogrib, and Cree Indian, perhaps forgetting ancient feuds and barbaric dances, spend happy hours listening-in while CJCA amuses them with music and song, and all the news of the great world of the White Man, that lies beyond the doors of their forest wilderness.

The *Journal* opened its first radio station May 1, 1922, installing a Marconi Wireless Co. YC 3 type radiophone set, the normal input being 500 watts, and on a wavelength of 450 meters, the antenna output was 3 amperes.

JUST A BIT TECHNICAL

THE transmitting gear consisted of transformed 100 volt A. C. to 6000 volts A. C., which was rectified on one side by a rectifying tube, and a series of condensers employed to smooth out the fluctuations, and the resultant supplied the plate of the 500-watt valve. Grid modulation was the method used to modulate the output at voice frequencies.

This set gave successful transmission as far as Tampa, Florida. A new station was installed



SERGEANT THORNE

Of the Royal Canadian Mounted Police, who is an enthusiastic radio fan. He hopes to have radio installed this year at the police post at Herschel Island where he now is arranging details for the execution of two Eskimo murderers



MRS. THORNE

Wife of the gallant police sergeant of the Arctic. Her favorite hobby is listening-in whenever she can get near a radio set—which isn't often, since she is usually far up in the Arctic regions, where radio is considerable of a rarity

on April 23, 1923. The set is unique in the fact that none of the usual electrical machinery is used in its operation, the main source of electrical energy being supplied directly from the domestic 110 volt 60 cycle lighting circuit. A transformer supplies on the secondary side, 10,000 volts, having a capacity rating of 3 K. V. A.

CJCA's schedule, Mountain time, is as follows:

12:30 noon, reports.

7:30 to 8 P. M. Childrens' half-hour.

8:30 to 9:30 P. M. Evening concerts.

11:15 P. M. Thursday nights. Igloo Hut meetings.

Tuesday and Saturday nights at 10 P. M., calls to stations in the North West Territories are given.

(The Igloo Hut is the name of a radio club of clever and enthusiastic musicians, whose programs are always received with delight by the fans.)

Announcing Some Announcers

WDAF

WOAW

WOS

WWJ



AT WOAW

Is Gene Rouse, a genial announcer at this popular and well-known station

AT WOS

Is J. M. Witten, announcer and program director of this station in the capitol city of Missouri

© Underwood & Underwood

AT WDAF

Is Leon J. Fitzpatrick, who is chief announcer of the station, "Happy Lark" of the famous "Nighthawk Frolic", and radio editor of the *Kansas City Star*



AT WWJ

Is Edwin L. Tyson, whose measured, calm accents are a pleasant event in the lives of radio listeners throughout the Middle West

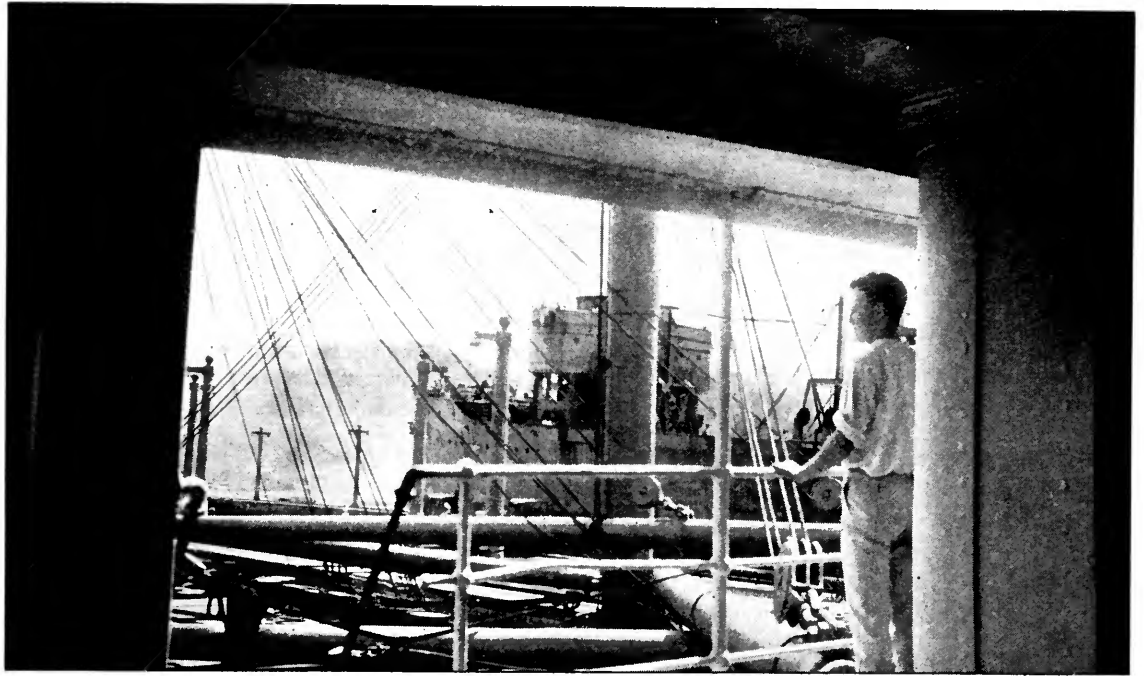

A Word from the Enemy

A Ship Operator Talks with and about His Friends the Broadcast Listeners and adds Some Constructive Suggestions

By R. E. SHLUKBIER

Commercial Radio Operator

DURING the two long years the sailor member of the family had been gone, he had completely encircled the globe in the capacity of radio operator on a tramp freighter. It was with some emotion, therefore, that he rushed home and let himself in through the door.

Things seemed strangely quiet inside but an entrancing odor from the kitchen reassured him. Dubiously he moved through the rooms to the kitchen where he stood speechless with wonder. There sat Grandma, all unconscious of his presence, or of anything else for that matter, a pair of phones clamped over her ears, darning socks. She was nodding her head in regular momentum, and—were his eyes deceiving him, or was just the slightest rhythmic motion of her shoulders perceptible? Suddenly she was all attention, her hands moved deftly through a maze of cardboard tubes and

a seemingly hopeless mixture of wires, and a half dozen knobs were given a slight adjustment. Then the contents of a pot on the stove was energetically stirred and the socks darned again—double speed.

“Grandma! What in the world——”

After the stormy greeting in which Mother joined from upstairs, came questions about the mysterious contraption. “Oh!” said Grandma, “Clare made it and you know they don’t play many gramophone records any more. I was just listening to dance music played by Dan’s Orchestra. You remember him don’t you?”

Afterwards the wanderer was given a rousing welcome by Dad and quite stampeded by his brother Clare, one of those indescribable American youths possessed of an insatiable curiosity. At dinner the conversation again swung to radio and it developed that the youngster had a mania, not for radio lyric sopranos or

bedtime stories, but for long-distance reception. He completely confounded the family with a volley of technical terms, mildly amusing his brother, Dad, and Mother. Grandma openly worshipped.

Looking askance at Dad whose dial twistings had produced no startling results, he claimed having received Pittsburgh and defiantly boasted that the new set he was going to build (when he got the money) would bring in the stations in the Middle West.

HOW TIMES HAVE CHANGED

SO THIS was the result of giving that young upstart a few crystals and coils of wire two years before to enable him to listen to an amateur who was at intervals broadcasting gramophone records. Slowly all the story was unfolded: A near-by station had started broadcasting music regularly which greatly stimulated his interest. The young rascal stole or borrowed every radio publication obtainable, tried every possible crystal combination, and by hoarding quarters exacted from Dad under various pretexts and the regular half dollar from Mother on Saturday he finally got an audion.

To the credit of his nimble mind be it said that Dad did not discover that filament current was necessary for the operation of the audion nor did he discover its source until an irate neighbor followed two wires from the battery of his Ford through the kitchen window to a table in a corner where Grandma zealously preserved a hiding place for these works of iniquity.

The Ford stood underneath an open lean-to close by and the neighbor seldom used it after he returned from work at night. Whether or not Grandma was entirely ignorant of the circumstances was not determined but that the shadow of suspicion should fall upon her made no especial difference. Anyhow, the kitchen was her undisputed domain after supper and the rest of the family noted the youngster's doings only absently. Dad, now thoroughly alive to the gravity of the situation, let the taxes go by delinquent and purchased a storage battery.

Clare could not have acquired his present knowledge without paying the price in the way of ruined tubes and materials. After a little questioning in private, he diffidently admitted that Grandma had been contributing her egg money.

A few days later, materials for an up-to-date tuner and amplifier were purchased and the two

brothers combined their experience in the designing of a receiver. Dad built the cabinet and after the first demonstration retracted entirely his prediction that he would not get any enjoyment out of a loud speaker. He had heard one of the screechy things somewhere down town. The music produced was mellow and well modulated. Radio got a boost and the professional operator was awakened to the fact of its existence for a new purpose.

When Clare's brother again went to sea, he listened for the music and was surprised to find how consistently he could hear the same voice and the same music heard by the folks at home. Even in the far-off Pacific on the way to the Orient he occasionally heard music from home.

IN ONE SHORT YEAR

ON NEARING the American coast on the return voyage, he was astonished to hear many new broadcasting stations. Stations in practically every state were heard. On his arrival home he found that long-distance reception had become the regular thing and that Clare at times was picking up stations a thousand miles away with loud-speaker volume.

However, they complained of code interference. It seemed to be the fashion to blame this on the telegraph amateurs and so Clare berated them with zeal, backing up his charges with various magazine accounts of like interference. It was amusing to read these obviously inaccurate accounts and the occasional replies from the amateurs who countered with insidious remarks about non-selective receivers, if indeed they were not too busy to say anything at all.

Clare tuned-in a station and his brother found that the chief offender was a powerful commercial station a few miles away whose broad spark could not be tuned out at that distance even though the receiver was unusually selective. These interfering signals from this busy station were so continuous that the concerts were practically demoralized and Dad had lost interest altogether. A Navy station also contributed some disturbance but the amateurs who seemed to have sharply tuned transmitting apparatus were seldom heard even though a few rotary spark notes and a few key thumps seeped through. They tried wave traps and directional antennas, with but mediocre success.

After another interval of a few months the commercial and Navy stations installed tube sets which left the local concerts undisturbed.

On the other hand, broadcasting wavelengths had been changed, the individual receiver's range increased by the addition of radio-frequency amplifiers and code interference was worse than ever when one tried to receive outside stations. It was also noted that the long-suffering amateur was no longer abused and that the wrath of the irate fans was transferred to the unsuspecting commercial operator, whose broad waves overlapped the broadcasting when he used his 450-meter wave. Publications were beginning to say things about ship-to-shore communication and government officials were complaining about not having sufficient funds to cope with the situation.

THE PROBLEM OF CODE INTERFERENCE

SINCE the writer at times probably contributes to this interference he will suggest a few of the conditions confronting the commercial operator at sea.

Many ships have been furnished with continuous wave transmitters working on a wavelength of 2,400 meters with the object of relieving the congestion on 600 meters and incidentally to increase their working range.

Changing conditions of the past five years, however, have more than defeated the purpose.

The shore transmitters have been tremendously improved and the receivers on board ship are now very sensitive. New commercial shore stations on the east coast can be heard the length and breadth of the Atlantic and they communicate directly with ships as far east as Gibraltar and west for hundreds of miles into the Pacific.

It is not easy to communicate over long distances successfully through this 600-meter confusion, and so wavelengths not so crowded are resorted to. A 706-meter wave was assigned but it is too close to the 600-meter wave and to

the 800-meter compass station wave to be entirely practical and so the 450-meter wave which is giving the music listeners all the interference, is used. This wave cannot be used during most of the broadcasting hours of the local stations, but it is doubtful that the signals of a distant ship are very noticeable through the loud signals of a local broadcasting station and so the listener is still annoyed when he tries to get a little thrill out of midnight DX reception.

While a fan is patiently turning his dials in search of China, a host of ship operators are also trying to get DX, and this is not nearly as easy as is generally supposed. It often happens that when a wireless operator tells about communicating directly with his home port several thousand miles away, the listener will not be impressed. In fact, the idea among the uninitiated seems to be that, consistent with the

other wonders of the century, one must but press the key to bid dreamy Honolulu a fond good-night or to ascertain via Hamburg, the status of good German sauges.

Desirable as this condition may be, it is not as yet realized and the operator is still apt to be in-

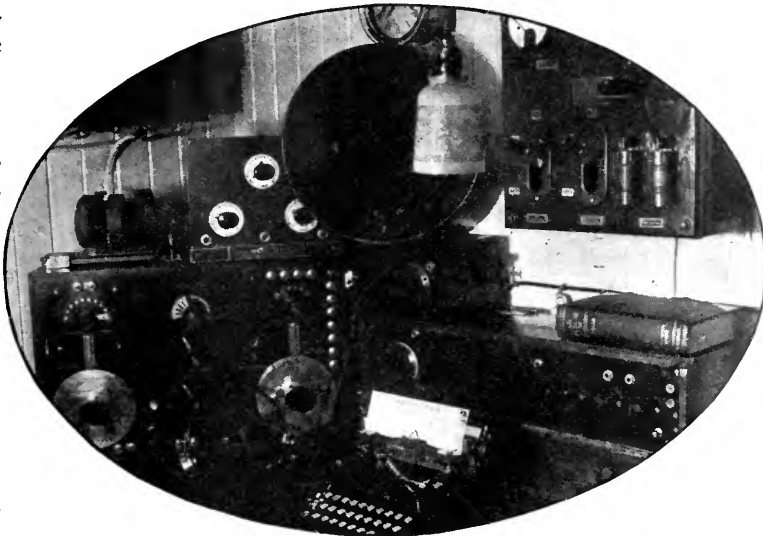

WHERE THE ENEMY LURKS
A corner in radio on a cargo ship

gloriously balked by a paltry few hundred miles and send his dots and dashes with a persistency born of desperation as an angry captain moves heaven and earth in his insistence to dispatch this message or that.

THE SHIP OPERATOR HAS HIS TROUBLES

OVER a distance of a few hundred miles, communication is very easy, but beyond that, especially on runs through the tropics, static will sometimes demoralize communication altogether even over short distances. Besides there is the ever-present and obnoxious problem of interference. Interference is becoming more and more serious because of the

increased working ranges the ship operators are expected to cover.

Last winter, ships occasionally managed to get their signals through to New York from the Pacific, and this season it is being done nightly. A station will not as a rule respond the first time it is called since any number of ships within several thousand miles may be calling it, and so the air is crowded with a steady repetition of the same signals until the desired

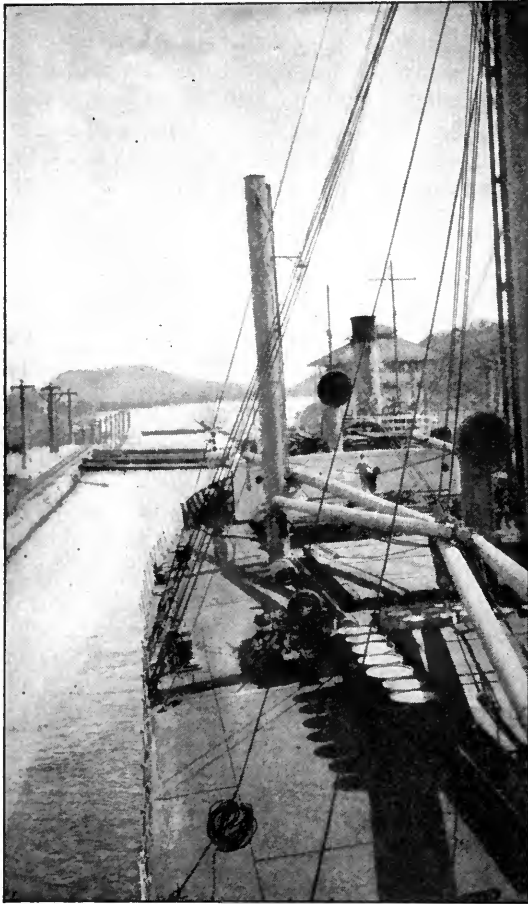

IN THE PANAMA CANAL
Mr. Shlukbier's ship in a quiet moment

station is either raised or daylight overtakes the ship, putting an end to DX work until night falls again.

Since passenger ships are equipped with continuous wave transmitters taking the load of love and kiss messages from the 600-meter wave, and cannot therefore disturb the broadcast listener, someone may wonder why a freighter so far away should wish to get in

touch with the home port and whether or not all this interference is necessary. That is exactly what all operators worthy of the name are asking themselves.

À BAS T R REPORTS

IT IS safe to say that over half of the signals are caused by unpaid position messages known as T R reports. Their primary object was to notify a shore station that a certain ship was within range. These reports have degenerated into a general contest for reaching either New York or San Francisco according to the location of the ship. It is true that these reports are printed by newspapers in some sections of the country. These reports should only be sent through the normal ranges of a coast station, or better still, daylight range, and a ban should be put on their transmission at night. This would be more effective in reducing the amount of interference than all the tube sets which could be installed for years to come.

There are also other violations of radio operating regulations which cause needless interference. The government officials rely almost entirely upon the operators themselves to report these. It is quite characteristic of the American operator to assume a tolerant attitude, and actually very few reports are forthcoming. A possible remedy would be to appoint certain ships with reliable operators as traffic ships giving them authority to stop unnecessary signals. They would be supplied with official cards to be sent to offenders warning them that a second offense would be made the subject of an official report.

Reduction of interference would also increase the reliability of radio for the protection of lives at sea which is its ultimate reason for existence. At present a ship in distress forced to use a low-powered emergency set would probably not be heard at all unless by some ship very close by. This situation may explain some of the mysteries of the deep. Moreover it often happens that an operator has an important message and is unable to put it through on account of unimportant traffic which is causing this external interference.

The broadcast listener can be assured that in time all code signals will disappear from the broadcast wavelength, although a certain amount of it will be encountered for some time. Meanwhile this disturbance should be regarded with tolerance.

WHO IS TO PAY FOR BROADCASTING AND HOW?

*A Contest Opened by RADIO BROADCAST
in which a prize of \$500 is offered*

What We Want

A workable plan which shall take into account the problems in present radio broadcasting and propose a practical solution. How, for example, are the restrictions now imposed by the music copyright law to be adjusted to the peculiar conditions of broadcasting? How is the complex radio patent situation to be unsnarled so that broadcasting may develop? Should broadcasting stations be allowed to advertise?

These are some of the questions involved and subjects which must receive careful attention in an intelligent answer to the problem which is the title of this contest.

How It Is To Be Done

The plan must not be more than 1500 words long. It must be double-spaced and typewritten, and must be prefaced with a concise summary. The plan must be in the mails not later than July 20, 1924, and must be addressed, RADIO BROADCAST Who Is to Pay Contest, care American Radio Association, 50 Union Square, New York City.

The contest is open absolutely to every one, except employees of RADIO BROADCAST and officials of the American Radio Association. A contestant may submit more than one plan. If the winning plan is received from two different sources, the judges will award the prize to the contestant whose plan was mailed first.

Judges

Will be shortly announced and will be men well-known in radio and public affairs.

What Information You Need

There are several sources from which the contestant can secure information, in case he does not already know certain of the facts. Among these are the National Association of Broadcasters, 1265 Broadway, New York City; the American Radio Association, 50 Union Square, New York, the Radio Broadcaster's Society of America, care George Schubel, secretary, 154 Nassau Street, New York, the American Society of Composers and Authors, the Westinghouse Electric and Manufacturing Company, the Radio Corporation of America, the General Electric Company, and the various manufacturers, and broadcasting stations.

Prize

The independent committee of judges will award the prize of \$500 to the plan which in their judgment is most workable and practical, and which follows the rules given above. No other prizes will be given.

No questions regarding the contest can be answered by RADIO BROADCAST by mail.

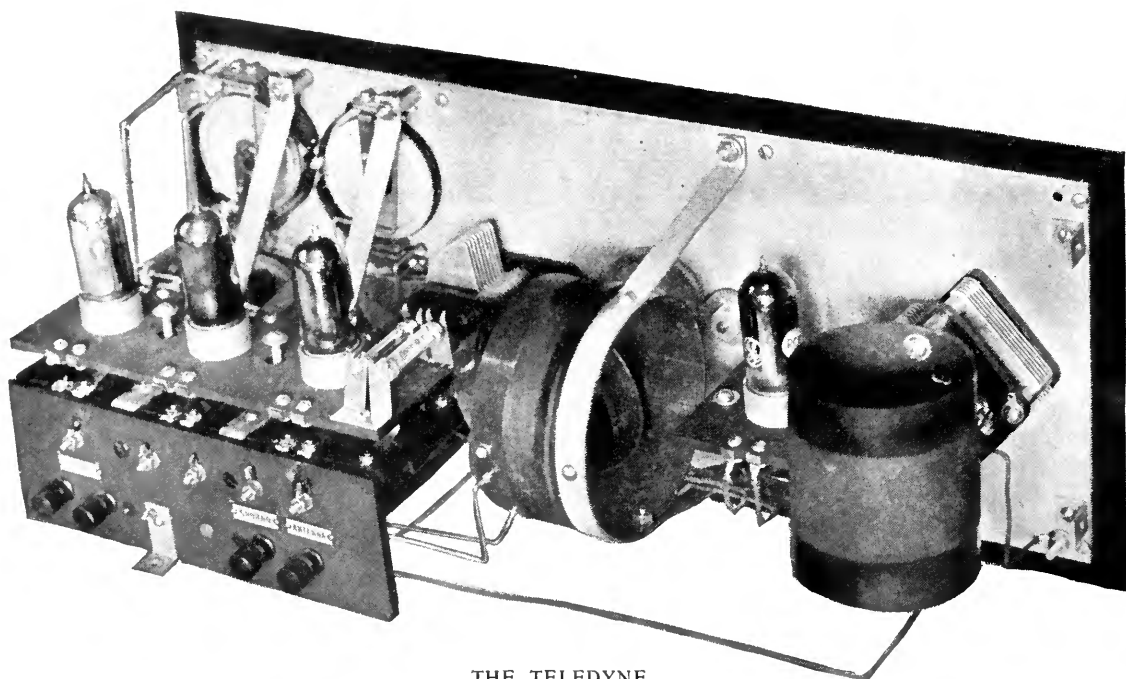

THE TELEDYNE

Rear view of a completed commercial receiver. The home constructor by using good parts which he may select himself and mount on a panel as suits him best, can easily build this set

How to Build a Teledyne Radio Receiver

By BOWDEN WASHINGTON

Chief Engineer, Cutting & Washington Radio Corp., and designer of the Teledyne

In RADIO BROADCAST for May Mr. Washington in "Regeneration Without the Squeal" described the commercial form of the receiver which he has designed to get volume and distance without unneighborly radiation. This is his how-to-build-it article on that receiver.—THE EDITOR.

THE principle of regeneration is undoubtedly of great value inasmuch as regeneration increases the usefulness of a vacuum tube up to perhaps a hundred times. On the other hand, regeneration as applied to the conventional type of single-circuit broadcast receiver (and to a lesser degree to the two-circuit type), becomes a menace to the whole future of home radio. This, of course, is on account of the possibility of these receivers transmitting, "re-radiating" as it is incorrectly called, though it is not the re-radiation but merely simple radiation which causes most of the trouble. As any one who lives in a town of any size

knows, the interference created by these receivers has practically ruined distant reception.

It seems, however, unwise to discard this highly useful and quite economical method of sensitizing a tube, and in a search for a regenerative receiver which would not create interference, the Teledyne was developed.

This receiver consists of a tuned radio-frequency amplifier, which is entirely stable and shows no tendency to oscillate, a fully regenerative detector, and the usual two audio-frequency stages. With four UV-199 tubes, used in conjunction with a hundred-foot, single-wire antenna, it is possible to obtain loud speaker signals on fairly distant stations.

In comparative tests against a five-tube neodyne, I have found that this circuit gives considerably more volume. It is also highly selective, and extremely easy to tune. The detector may be set into oscillation and the "carrier wave whistle" picked up without fear of creating any appreciable outside interference.

The radio-frequency amplifier operates in approximately the following manner:

Its grid inductance is also the antenna tuning inductance. Its plate inductance forms a delivery coil and transfers its output energy to the detector grid inductance, which is tuned by the usual parallel variable condenser. The output of a vacuum tube (somewhat like a dry cell) is greatest when the external impedance of the output circuit is equal to the internal impedance of the output side of the tube. By properly proportioning the inductance and coupling of the delivery coil, the impedance of the detector grid circuit may be made to "show through" into the amplifier plate circuit at this correct impedance value when the detector grid circuit is tuned.

THE CONSTRUCTOR HAS PLENTY OF LEEWAY

IN GIVING directions as to the construction of the Teledyne, I have purposely omitted any detailed panel drilling layout, but have

shown instead the correct layout of the various parts. My reason for this is that I do not wish to recommend any particular makes of parts; a particular make may not always be available, and the constructor may have at hand certain perfectly appropriate parts of a make other than that specified, which he would be justified in using rather than purchasing new ones. Good parts, of course, should be used. It is important to keep the radio-frequency layout approximately as shown, as it is absolutely essential that no coupling shall exist between the two grid inductances. This means that the radio-frequency grid inductance should be mounted at some little distance from the detector grid inductance and horizontally. The detector grid inductance should be mounted vertically, and in such a position that an extension of the axis of the radio-frequency coil would pass through the middle turn of the detector grid winding, and at the same time intercept the axis of this coil.

The arrangement of the audio amplifier is of course optional with the builder, though some simple shock absorber mount such as that indicated should be devised for the detector and the two audio amplifier tubes. As all four tubes will be used at all times except for local reception, but one rheostat is shown for sim-

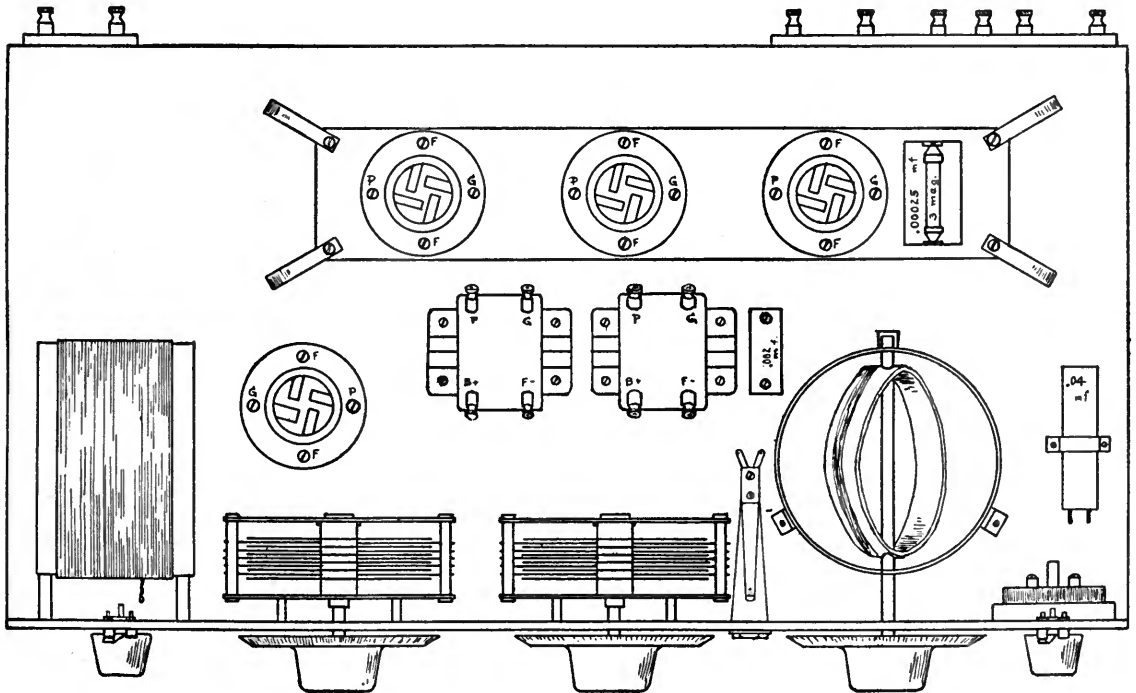

FIG. 1
Plan view

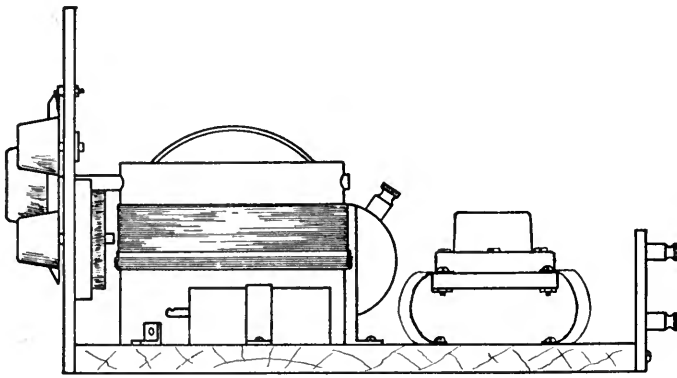

FIG. 2
Right Elevation

mfd. (This condenser is at all times across the B battery, and if leaky will run this battery down. To test for leaks place the condenser across 90 volt B battery, remove it, wait several minutes and discharge the condenser with a piece of metal. A quite noticeable spark will occur if the condenser is faultless).

- 11 binding posts.
- 150 ft. No. 26 D. S. C. wire (double silk covered)
- 10 ft. No. 30 D. S. C. wire (double silk covered)
- 1 3-point jack.
- Miscellaneous wood and machine screws, strip brass, regeneration coil shaft, flexible pigtail material for regeneration coil and tube mount leads, phosphor bronze strip $\frac{5}{14}$ " x 26 gauge for shock absorber spring, etc.

BUILDING THE TELEDYNE

plicity, and a two-point switch is provided, so that the loud speaker may be operated on one or two audio stages.

These are the necessary parts of the complete Teledyne as shown:

- 1 panel 2" x 1 $\frac{1}{2}$ " x $\frac{3}{16}$ "
- 1 panel 6" x 2 $\frac{1}{2}$ " x $\frac{3}{16}$ "
- 1 panel 19 $\frac{1}{2}$ " x 6 $\frac{1}{2}$ " x $\frac{3}{16}$ "
- 1 wooden base board, preferably laminated 19 $\frac{1}{2}$ " x 10" x $\frac{1}{2}$ "
- 2 good variable condensers .00025-.0003 micro farads.
- 3 3 $\frac{1}{2}$ " dials.
- 2 Instrument type switches with bushings.
- 4 switch points.
- 4 switch stops.
- 1 pc. tubing 4" outside diameter, 2 $\frac{3}{4}$ " long, $\frac{1}{16}$ " wall
- 1 pc. tubing 4" outside diameter, 3 $\frac{1}{4}$ " long, $\frac{1}{16}$ " wall.
- 1 pc. tubing 3 $\frac{1}{4}$ " outside diameter, $\frac{3}{4}$ " long, $\frac{1}{16}$ " wall.
- 4 good sockets for UV-199 tubes.
- 2 audio transformers.
- 1 Seven to 12 ohm rheostat with "off" position and knob.
- 1 good .00025 mfd. mica grid condenser.
- 1 3-megohm leak.
- 1 good .002 mfd. mica condenser.
- 1 paper telephone condenser of any capacity above .04

I WOULD rather leave the exact details to the individual constructor for very much the same reason that I do not wish to specify makes of parts. I believe the average person who has arrived at the stage of building his own four tube set usually has a fair accumulation of odds and ends, some of which certainly can be used. A suggested layout is shown in Fig. 1. The radio-frequency grid inductance is shown at the left, supported from the panel by separators which may be cut out of brass tubing with a hack saw, and this coil may also be fastened to the base with two wood screws at its point of tangency. Mounted on the panel in front of it will be seen a two-point switch which includes either 50 or 80 turns in the antenna circuit. This is necessary to cover the entire broadcast wavelength band on all sizes of antennas. Next is the antenna tuning condenser, followed by the detector tuning condenser. The jack shown is of the "three-point" type. Loud speaker binding posts are

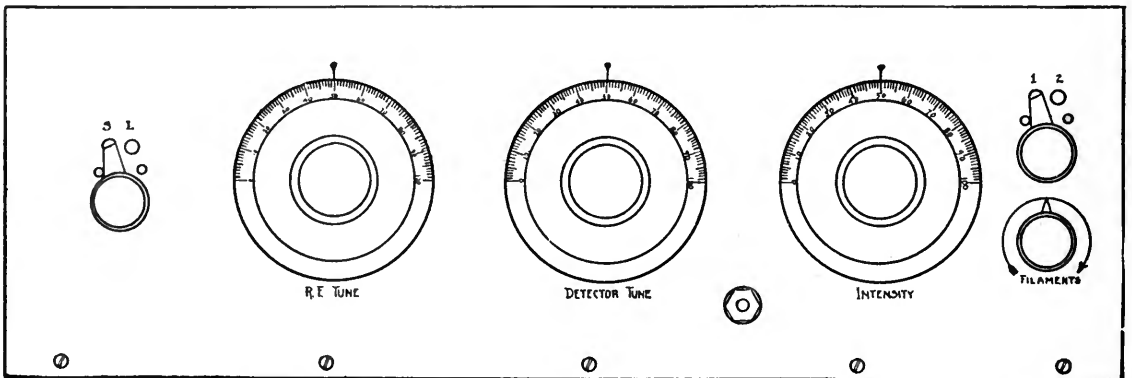

FIG. 3
Front elevation

provided on the rear terminal board, and the jack is so wired that when the telephone plug is removed, the loud speaker is automatically cut in. This is rather a nice arrangement, as it enables the user to "fish" for distance and get the tuning done on his telephones, and then by merely pulling the plug half way out, flood the room with music from a distant station.

Next comes the detector grid inductance mounted vertically with the detector regeneration coil. The rheostat, B battery condenser, and one two-stage switch are at the extreme right.

I have shown the detector and two audio tubes mounted on a strip of bakelite or wood and sprung from the base by four U shaped phosphor bronze strips. It is suggested that a straight wire be run along the filament connections on the sockets and that two of these spring supports be used to carry the filament current. There is no need of a vibration-proof mounting on the radio frequency tube.

It is convenient to use the right hand socket on the strip for the detector tube, the middle socket for first, and the left for second audio frequency stage.

The small terminal board at the left contains the antenna and ground binding posts. The larger board at the right carries plus A, -A, -B, plus $22\frac{1}{2}$, plus 90, plus C, -C and two posts for the loud speaker.

All winding of the coils should be done exactly as shown in Fig. 4. Notice that a strip of well shellacked cardboard $\frac{1}{4}$ " thick is laid over the detector grid inductance at the filament end before the four-turn delivery coil is wound in place. Note also that this delivery coil begins over the first turn of the detector winding.

All wiring should be made as short and direct as possible, and all joints soldered with resin cored solder. Do not use either paste or acid.

Fig. 5 shows the connections of a Teledyne.

TUNING THE RECEIVER

THE Teledyne is extremely simple to tune, but of course requires some practice. Real volume on long distance is only usually obtained by a final readjustment all around. A vernier is not necessary, and for that reason I have not shown it, but a vernier on the detector tuning condenser, either mechanical or electrical, is undoubtedly an aid to making the final adjustment.

There are two general methods of tuning the Teledyne, the first is the familiar beat note methods whereby the detector is made to oscillate by increasing the regeneration control. The secondary or grid circuit tuning adjustment is then varied, and the various beat-notes

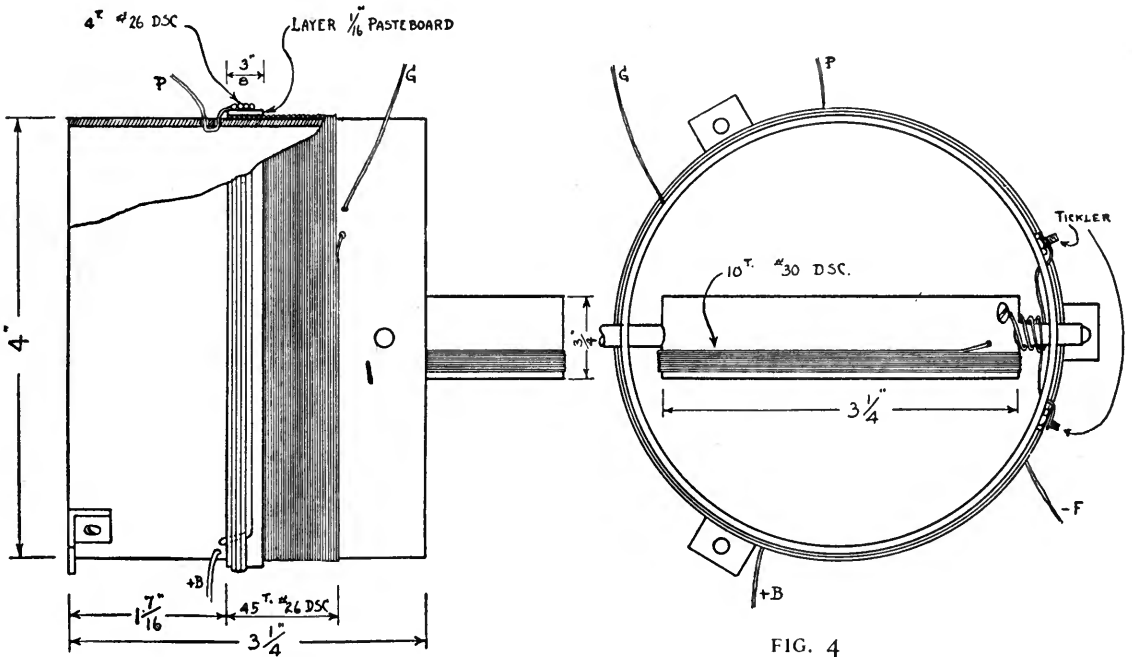

FIG. 4
Detector grid coil, R. F. plate coil and regeneration coil

of the stations broadcasting will be heard. One of these is chosen, and the antenna circuit is then tuned to this wave by varying the antenna series condenser until the beat-note is loudest. The regeneration is then reduced until the beat-note disappears, and the received program is clear.

The second method of tuning is similar to that employed with the neutrodyne type of receiver, with the exception that only two controls are necessary. The regeneration is reduced to a low value, and the antenna and grid circuit tuning adjustments are then simultaneously varied, and held in tune with each other as the entire scale is covered. The process is exactly similar to that of tuning the neutrodyne, except that it is much more rapid.

The tuning adjustments are almost entirely independent of each other, so it is readily possible to record the dial settings of the antenna and grid tuning adjustments for every station heard, and thus keep a permanent record of these stations. By reference to this record the dials may then be set for any particular station, at any time, and that station will be received without the necessity of retuning.

THE ANTENNA

THE antenna used depends largely on the location of the receiver. Like most receivers, it is somewhat more selective on a

short antenna. If located within five miles of a large broadcasting station, I would recommend a single wire, with an overall length from the receiver to the far end of 65 ft.; if located at a greater distance from a powerful transmitter, lengths up to 150 ft. may be used. The best available ground should be used, usually a good, clean connection to a cold water pipe. Sandpaper both the inside of the ground clamp and the pipe.

One word of warning—never burn the filaments of UV-199 tubes hotter than is absolutely necessary for good reception. Burning them too hot does not increase their response, but does boil the thorium off the filaments, and this in a short time ruins the tube. This is sometimes rather disconcerting, as the tube, of course, lights and appears normal, but it is either feeble or totally inoperative. There is no need of this happening however, if the above precaution is taken.

The Teledyne can be used quite successfully even on distance, with a ten foot indoor antenna, though the results are naturally not as good as if an outdoor antenna is used.

On a ten foot wire running from the set to the picture molding, the writer has received adequate loud speaker signals in Minneapolis from Omaha, Chicago, St. Louis, Davenport, Cleveland, and Pittsburgh.

It must be remembered that there are oc-

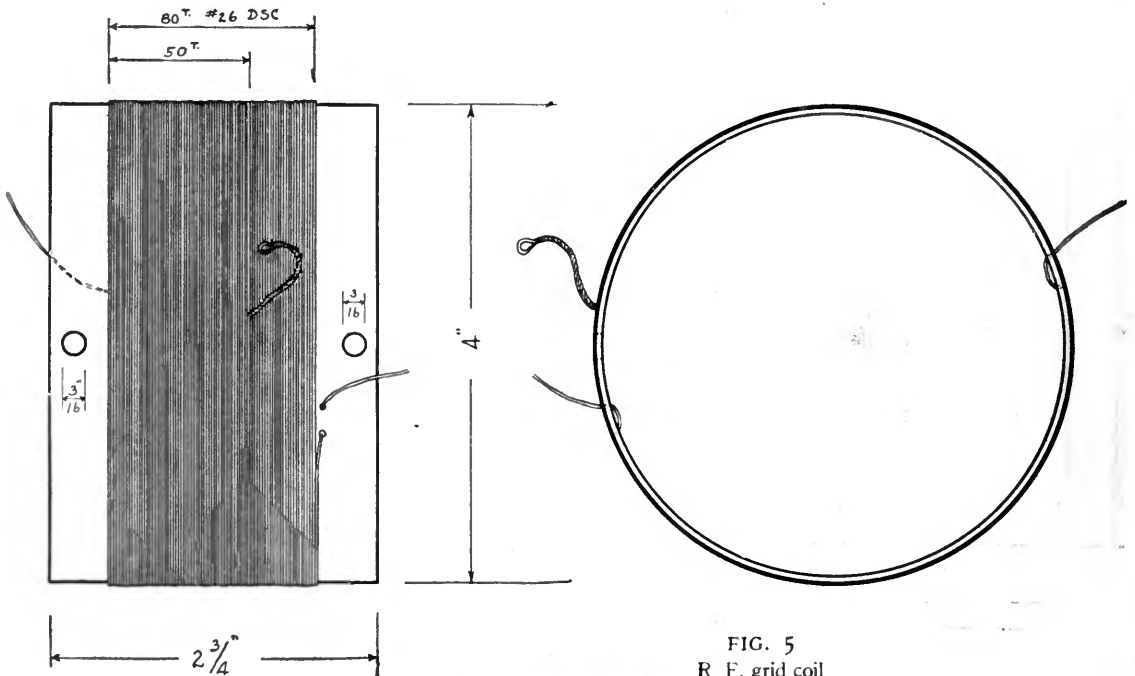

FIG. 5
R. F. grid coil

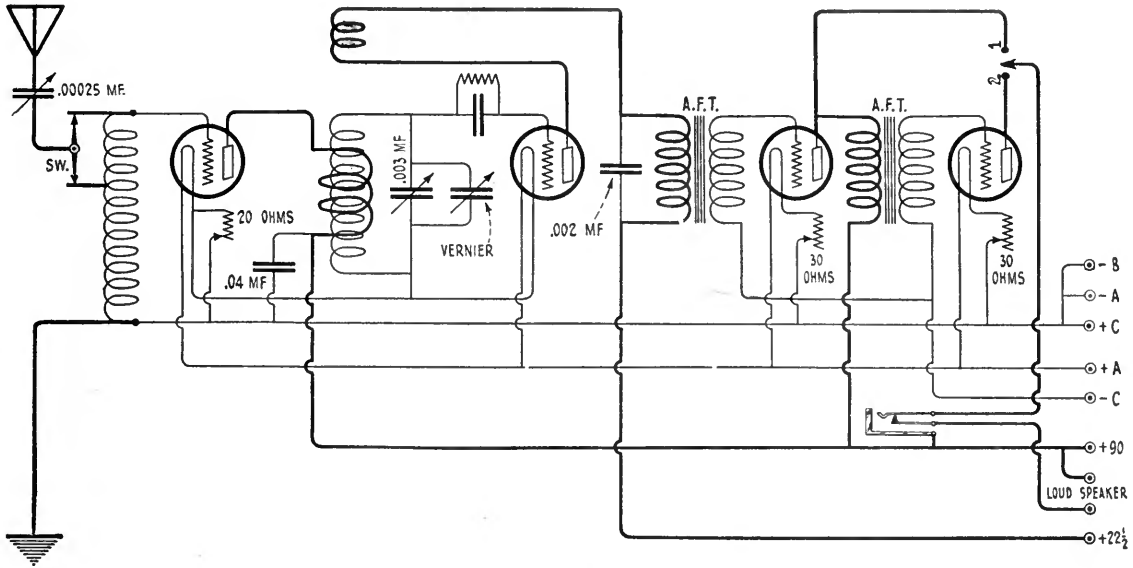

FIG. 6
Complete diagram of connections of the circuit

casional buildings which owing to the large amount of metal used in their construction act as a shield, in which case an indoor antenna is not satisfactory.

In using a short indoor antenna connect as follows:

1. Connect the ground lead in the usual manner.

2. Connect a fixed mica condenser of 125 micro-micro-farads capacity between the antenna and ground binding posts. This size is sometimes difficult to obtain. Two 250 mmfd. Dubilier grid condensers may be used in series.
3. Connect the ten foot antenna directly to the grid of the radio-frequency tube.

WHAT the farmer gets out of broadcasting is the subject of an interesting article by Robert H. Moulton which will appear in RADIO BROADCAST for July. Mr. Moulton tells how the farmer gets something out of the air besides music and how his radio receiver is paying him dividends.

The Uses of the Three-Electrode Tube

WHAT MAKES THE WHEELS GO 'ROUND: IV

By WALTER VAN B. ROBERTS

Readers who wish to have available a fund of reliable radio theory more up to date than most textbooks will do well to keep this series of articles by Mr. Roberts. All of these articles, while treating of the general subject of radio theory, are complete in themselves and each installment is comprehensible alone. This is the fourth of the series which began in this magazine for March.—THE EDITOR.

THE three-electrode tube can be used in a great many ways, but its use in connection with radio transmission and reception is confined almost exclusively to the following:

1. Modulation, or the process of varying the amplitude of the transmitted radio waves in accordance with the variations of air pressure that constitute the voice or music.
2. Demodulation (also called rectification and detection) or the process of converting modulated radio-frequency alternating cur-

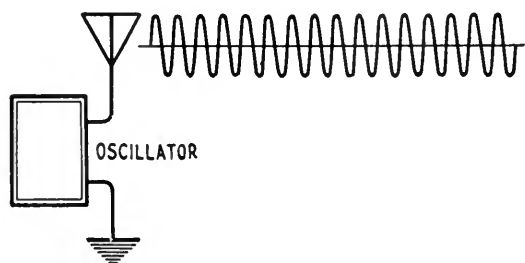

FIG. 14

How an unmodulated continuous radio wave may be diagrammed

rents into direct current varying in strength in accordance with the original voice or music.

3. Regeneration, a process for neutralizing some of the unavoidable resistance in the receiving circuits, resulting in greater currents being produced by the incoming waves.

4. Amplification, or increasing the energy of either radio- or audio- (voice or music) frequency currents, without changing their form.

5. Oscillation, or the production of high frequency alternating currents. At the transmitting stations it is high frequency current flowing in the antenna that radiates energy under the name of wireless or radio waves.

37. MODULATION

THE simplest case of modulation occurs when a pure note of a single frequency, such as produced by a tuning fork, is transmitted. When no sound is supplied to the transmitter or microphone the transmitting station is sending out radio waves of a single frequency and constant amplitude as shown in Fig. 14. But if an air wave or variations of air pressure from a vibrating tuning fork hit the microphone as shown in Fig. 15 then the modulating apparatus causes the amplitude of the radio waves to vary in accordance with the tuning fork wave. If the original radio wave be represented by $\sin pt$ and the air wave from the tuning fork by $\sin qt$ then the modulated radio wave would be of the form $\sin pt (1 + m \sin qt)$ where the constant m shows the degree of modulation, that is, how large a percentage change in the amplitude of the original radio wave is caused by the modulation. (if $m=0$ the wave would not be modulated at all. If $m=1$ the amplitude would periodically fall to zero as shown in Fig. 16.)

38. ANALYSIS OF MODULATED WAVES*

NOW the surprising part about the modulated wave is that it can no longer be considered to have a single frequency. For by a simple trigonometric formula we can show that $\sin pt (1 + m \sin qt) = \sin pt + \frac{m}{2} \sin (p+q)t + \frac{m}{2} \sin (p-q)t$ which shows that the modulated waves must be treated as the sum of three different trains of constant amplitude

*The starred sections may be omitted on the first reading, since these parts are rather more technical than the main part of the series.

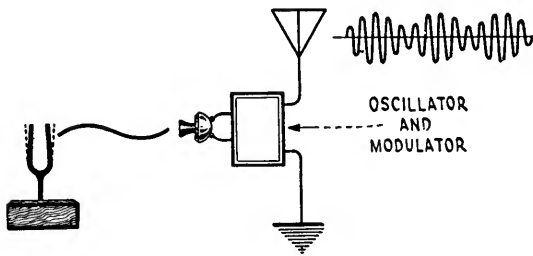

FIG. 15

A continuous radio wave modulated by an audio-frequency impulse from the tuning fork

waves of frequencies respectively: 1, the same as the frequency of the original unmodulated radio wave, which is called the "carrier" frequency; 2, a frequency greater than that of the carrier by the signal frequency; and, 3, a frequency less than the carrier by the same amount. That is, the carrier frequency being $\frac{P}{2\pi}$ and the modulating frequency $\frac{Q}{2\pi}$, then there will be sent out waves of frequencies $\frac{P}{2\pi}$, $\frac{P}{2\pi} + \frac{Q}{2\pi}$, and $\frac{P}{2\pi} - \frac{Q}{2\pi}$.

39. SIDE BANDS*

FOR very high quality music all tones between about 30 and 5000 vibrations per second should be transmitted with equal efficiency. To transmit the former we must, as explained above, transmit a frequency 30 cycles greater than the carrier and another 30 cycles less than the carrier, in addition to the carrier itself. To transmit the 5000 we must use the frequencies 5000 greater and 5000 less than the carrier. And to transmit all the intermediate tones, we must use the two bands of frequencies (called the upper and lower side bands) shown shaded in Fig. 17.

The whole range of frequencies used is called a "channel." In the case just described the width of the channel is 10,000 cycles. The important thing about all this is that broadcasting stations do *not* use only a single frequency or wavelength as might be supposed from the figure given in the newspaper radio programs (that figure is the frequency of their

carrier wave in kilocycles per second) but they each require a channel of definite width, and hence only a rather small number can work at once without their channels overlapping, which results, from the listener's point of view, in a continuous whistling sound (of high pitch if the channels overlap only slightly, and of lower pitch if the overlapping is greater).

40. RELATION OF FREQUENCY TO WAVELENGTH

RADIO waves travel with the speed of light, 300,000,000 meters per second. Now in any wave motion the frequency or number of waves passing a given point per second, multiplied by the wavelength, gives the speed with which the waves are traveling. If a train of railroad cars passes a given point at the rate of two cars per second and each car is fifty feet long, the speed of the train is obviously one hundred feet per second. Quite similarly, if the frequency of passing radio

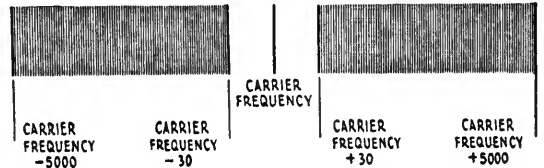

FIG. 17

The complex emitted wave is composed of a carrier frequency and two side bands. The whole is a "channel"

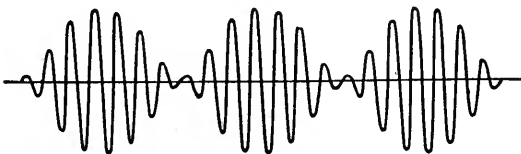

FIG. 16

waves is one million per second, then the length of each wave must be 300 meters to make the speed come out the value stated above. For a long time the term wavelength has been used rather than frequency, but at present the kilocycles seem to be displacing the meters. The reason for this is that if the frequencies of several transmitting stations are given, we need only make sure that no two are within about ten kilocycles of each other in order to be sure that they will not interfere. (Non-interference when waves are only ten kilocycles apart will of course only be true if a very highly selective receiving set is used, one that can pick up all the frequencies lying in one channel and none lying outside of it). On the other hand, if we work with wavelengths, we must calculate anew the width of channel expressed in meters for every different wavelength. Thus a 10-kilocycle channel at three hundred meters wavelength is only a three meter channel, while at three thousand meters wavelength, it is a three hundred meter

channel. There are about nine times as many ten kilocycle channels available between the wavelengths 30 and 300 meters as there are between 300 meters and 30,000.

41. MATHEMATICS OF A MODULATING AMPLIFIER TUBE*

FIG. 18 shows how a vacuum tube can be made to modulate. The grid is supplied by means of transformers with the carrier frequency and the modulating frequency. We now make use of the equation given previously for plate current, putting in the two alternating potentials along with the C battery potential.

$$i_p = K (B + \mu \times \text{grid potential})^2 = K (B + \mu [C + a \sin qt + b \sin pt])^2$$

$$= K [(B + \mu C) + \mu (a \sin qt + b \sin pt)]^2$$

$$= K (B + \mu C)^2 \text{ which is direct current}$$

$$+ 2K (B + \mu C) (a \sin qt + b \sin pt) \mu$$

which are currents of frequencies $Q/2\pi$ and $P/2\pi$

$$+ K \mu^2 a^2 \sin^2 qt \text{ which reduces to direct current and current of frequency } 2Q/2\pi$$

$$+ K \mu^2 b^2 \sin^2 pt \text{ which reduces to direct current and current of frequency } 2P/2\pi$$

$$+ 2K\mu^2 ab \sin qt \sin pt \text{ which can be resolved into currents of frequencies } \frac{P+Q}{2\pi} \text{ and } \frac{P-Q}{2\pi}.$$

Now of all three currents, only those of frequencies $P/2\pi$, $\frac{P+Q}{2\pi}$, and $\frac{P-Q}{2\pi}$ are near enough "in tune" with the antenna circuit to produce appreciable currents in it. Hence the antenna current and the radio waves caused by it, have the carrier frequency and the two side frequencies, and hence correspond to the modulated waves analysed in a previous paragraph.

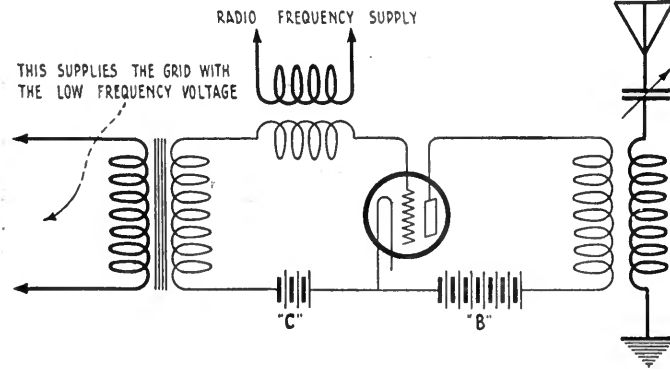

FIG. 18

A simple method of modulating a vacuum tube

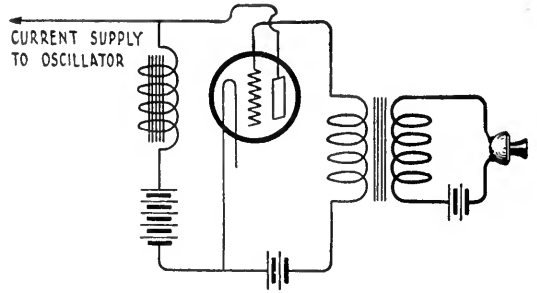

FIG. 19

A commoner method of vacuum tube modulation

42. THE HEISING SYSTEM OF MODULATION*

THE modulating circuit of Fig. 18 is not one commonly used: it was chosen because the mathematics of its operation is easily worked out from the equation for plate current. The circuit most commonly used is shown in Fig. 19. Two tubes are used. The one not shown in the diagram is the oscillator that supplies the antenna with radio-frequency current. The current supply for the plates of both tubes comes through the iron core inductance or "choke" coil which tends to keep the total current supplied to both tubes constant. But the voice hitting the microphone causes voice-frequency variations of current in the primary of the transformer which in turn produce voice-frequency variations of the grid potential of the tube shown in the diagram. These variations of grid potential cause the tube to draw a varying amount of plate current. But since the total current supply is kept constant, the oscillator tube must receive more whenever the other tube receives less and vice-versa. The more current the oscillator tube receives the more strongly it oscillates, while if it receives less current than normal, its oscillations are weakened. Thus, corresponding to the voice, we have variations in the radio wave amplitude, in other words the radiated wave is modulated by the voice. It might seem inefficient to use two tubes this way instead of one, but it is not so bad as it seems, for the oscillator by this method is part of the time being forced well above its allowable safe continuous output. This is the Heising system of modulation, and it is used in many of the most successful broadcasting stations.

43. SUPPRESSED "CARRIER" TRANSMISSION

THE carrier wave has no part in conveying intelligence. It is required only for the purpose of demodulation at the receiving end. It can be left out entirely provided that a local oscillator tube is used at the receiving end to supply current of the same frequency to take its place. The "balanced modulator" used to get rid of the carrier is shown in Fig. 20. Analysis of this circuit (which is merely two tubes, each acting in the manner previously taken up) shows that the two side bands generated by each tube act additively in producing current in the antenna, but the carrier frequency current in the plate circuit of one tube just cancels the effect of the carrier current in the other tube as far as producing current in the antenna is concerned. Much power is wasted transmitting the carrier, but for most purposes it is best to do so because it is difficult to make the local oscillator at the receiving station supply just exactly the same frequency. Another advantage in suppressing the carrier is that the locally generated carrier frequency at the receiving end is not subject to variations in strength and hence there is a reduction in the amount of "fading" of the received signals.

44. SINGLE SIDE BAND TRANSMISSION

FURTHERMORE, only one of the side bands is required to convey the speech or music, as will be evident from the complete analysis of demodulation given later on. If only one is used, the channel required will

only be one half as wide, which is an important feature if the ether is "crowded" with transmitting stations. Also, the receiving set can be made to receive only one half as wide a band of frequencies and hence offers only one half as much chance for static and other interference to get in. If both the carrier and one side band are suppressed, the local oscillator at

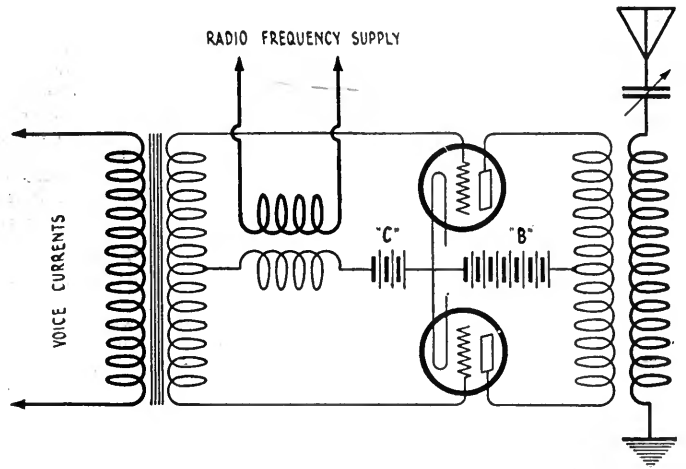

FIG. 20

A "balanced modulator" system which eliminates the carrier wave

the receiving end can be as much as fifty cycles different in frequency from the original carrier without serious interference with intelligibility of speech. However, the harmonic ratios in music would suffer. For the reasons mentioned above the American Telephone and Telegraph Co. are using single side band transmission in their transatlantic telephony tests. This system is not now practicable for short wave work as it is too hard to "filter out" the side band that is not wanted, when the width of these bands is only a small fraction of the carrier frequency.



THE SUPER-HETERODYNE

MAJOR EDWIN H. ARMSTRONG is writing his own story of his new super-heterodyne,—exactly as he described it before a recent meeting of the Radio Club of America,—exclusively for RADIO BROADCAST. The article will appear in July.

The super-heterodyne, one of the few new circuits brought out in recent years, was developed by Major Armstrong in France under war-time pressure and now is becoming constantly more popular.

Announcing: —

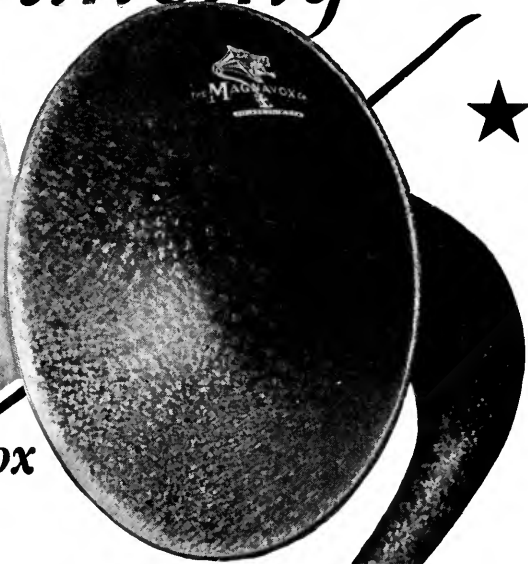

*A New Magnavox
M4
requiring no battery*

THE supreme achievement of Magnavox engineers represented in a Reproducer of truly *exquisite* tone quality.

The superb tone quality of M4 results from the perfection of the Magnavox semi-dynamic operating principle incorporating; *first*, a new magnetically balanced armature; *second*, an improved type of diaphragm supported by hollow rubber gaskets; and *third*, an extremely high resistance winding which makes M4 unusually sensitive.

Magnavox M4 and other Magnavox Radio Products can be had of good dealers everywhere

THE MAGNAVOX CO., OAKLAND, CALIF.

New York Office: 350 West 31st Street

Canadian Distributors: Perkins Electric Limited, Toronto, Montreal, Winnipeg

MAGNAVOX
The Reproducer Supreme

Price
\$25.00

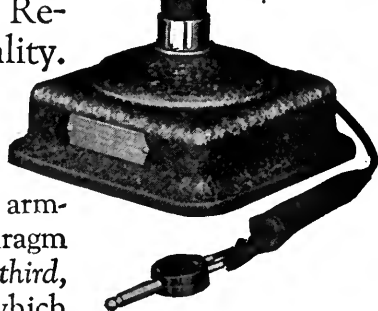

Beautifully finished in dark enamel with gold high lighting.

Equipped with flexible cord and Weston plug ready to connect as simply as a head set.

four hours because nothing will tune-out WDAF's harmonics while they have their alleged frolic, it can be expected that he will be in a different position to most other amateurs, so his feeling should not be taken as a general one.

It has often been remarked that the enforced quiet hours have reduced interference from amateur stations. This is a point which I should like to hear more correctly stated. It is true that when this regulation was made, some owners of single circuit receivers got less interference, but the general interference was not altered at all. Too many amateurs are going around confessing that their sets create interference, whereas, quite probably they do not. The spark is the only type of transmitter which I know does create interference serious enough to be noticed. I think that even an ICW set is harmless.

While in New York last year, I was listening to 2RK on a single-circuit receiver, at a point about a mile distant from him, and I found the tuning quite sharp. From experiments which I have made from time to time in the last five years, I am inclined to believe that if interference is encountered from a CW station, the fault is with the receiver. One should never lose sight of this point. As a matter of fact, the improvement in design of receiving sets is so rapid that I think the present compulsory silent period will be lifted in a year or so.

H. S. GOWAN,
Kitchener, Ont.

CARTOON-A-GRAM



My Boss Says, THE RADIO BROADCAST
MAGAZINE - HELPS HIM GET THE MOST
OUT OF RADIO

FROM

HOD THOMPSON
Box 307
Lytle Plains NY

NOT ALL "APPLAUSE"

Goes to broadcasters. This card, done in full colors, hove in the office not long ago

"To Begin With, Radio Saved My Life."

Editor, RADIO BROADCAST,
Doubleday, Page & Co.,
Garden City, L. I.

DEAR SIR:

You asked some time ago for letters telling "What Radio Has Done for Me." Well, to begin with, radio saved my life. This I did not fully realize until after my doctors had explained it all to me, but now I know it to be true.

Some two years ago, I found I had serious lung trouble. I tried to fight it "standing up" for a while, but soon my doctors sent me to Asheville, N. C., where I remained in a sanatorium and made no progress. Considering myself a gone goose, and preferring to die among my own family rather than passing out at Asheville, I came home, down and out. I practically gave up, and lost all interest in everything. The combined pleadings of my family and doctors to buck up, did not make any impression on me whatever.

One day a strange chap came into my bedroom and began to fool around with some wires and a box on a small table near me. He did not have much to say, and I was

in such a state that I thought he had something to do with my funeral. I rather thought that this stranger's presence was only another indication of the complete care my family was taking of me and that this was the real beginning of the end.

Then the chap said: "Say old man, try these on your head and see if they fit." I wondered whether people were now having their heads measured for burial. Anyhow he placed the contrivance over my head, and I don't think I have been before or since so near heaven as I was then. I heard a voice and music and actually believed I was leaving this earth.

Making a long story short, I became as interested as a six-year-old. The set was installed on Friday and on Monday, my doctors said to me, "You have made as much improvement in the last three days as we could have expected in a month. From then on, I lived in bed with the phones on. But I did not stay there very long. . . .

Not long ago I was out riding with my doctor, who remarked to me that I owed my complete recovery not to his good work especially, but to the beneficial effect of the radio set at the psychological time.

T. B. S.,
Atlanta, Ga.

A British Amateur Reports

Editor, RADIO BROADCAST,
Doubleday, Page & Co.,
Garden City, L. I.

DEAR SIR:

If you have space for the following, I would like to report reception of the following American radio amateurs. I used two valve, detector and one low-frequency valve. If any of them are interested and can verify same, I would be glad of a card.

Received on 25 November, 1923, about 10:30 P. M. E. S. T. 2CXL, 8MZ, 8TR, 8UF, 8AGO, 8CPD, 8CPO, 8XAW, 9CR, 9AMK, 2EL (working 5HL) 8AMM (working 9WC).

Received 10 February, 1924, about 8 P. M. E. S. T. 1ALJ, 1AOL, 1APY, 2OMF, 5AIR, 9ZL, 2CEI (working 5AIC), 8COI.

These dates and times are calculated in Eastern Standard throughout.

Yours truly,
A. C. SIMONO,
Wellington Road,
Mablethorpe, Lincolnshire,
England.

"Joy Unconfined"—about the Roberts Set.

Editor, RADIO BROADCAST,
Doubleday, Page & Co.,
Garden City, L. I.

DEAR SIR:

The sole fault I have to find with your famous one-tube knock-out reflex receiver is that users frequently run into a faulty fixed or variable crystal and as a result grow dissatisfied.

This is borne out by my own experience, for I have had wonderful results, when the crystal "was feeling well" on three different occasions with all conditions other than the crystal the same. So far I have tried several crystals. With one semi-fixed crystal I seemed to get the most satisfactory results—when that was adjusted right and fastened, I could get three to four hours of perfect reception. Then I had all Chicago stations, Detroit, Springfield (Mass), Philadelphia, Fort Worth, Dallas, Northfield, Atlanta, and once, Oakland, Cal., but apparently after that favored spot lost its sensitivity, the set would



“THE STANDARD OF COMPARISON”

ULTRADYNE

The Improved
SUPER-HETERODYNE

The Ultradyne employs the “Modulation System,” a basic development by R. E. Lacault, A. M. I. R. E., radio engineer of this company, and formerly Radio Research Engineer with the French Signal Corps Research Laboratories.

The “Modulation System” places the Ultradyne years ahead of all present methods of radio reception. This new principle increases the sensitiveness over that of any known receiver. Weakest signals are made to operate the loud speaker.

Results secured by Ultradyne owners are amazing and exceed even those obtained with any other receiver under the same conditions. For range, signal audibility and faithful performance, the Ultradyne commands your first consideration.

Write for descriptive Circular

PHENIX RADIO CORP.

5-7 Beekman St.

New York

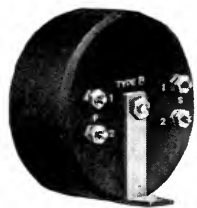

ULTRAFORMERS
Types “A” and “B”

New improved long wave radio frequency transformers. Type “B” may be successfully employed in any circuit where long wave radio frequency transformers are essential.

\$5.00

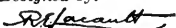
Designed by:



Send for 32-page illustrated book giving latest authentic instructions on drilling, wiring, assembling and tuning 6 and 8 tube Ultradyne receivers.

50 Cents

Edited by:

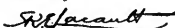

★ Tested and approved by RADIO BROADCAST ★

The Torrington Radio Club

TORRINGTON, CONN.

Radio Broadcasting Station _____

I wish to acknowledge reception of your _____

by _____ on _____

at _____ M., E. S. T. _____

Remarks: _____

Receiver used _____

PRINTED THANKS FROM THE RADIO CLUB

Members of the Torrington, Conn., Radio Club send these cards out to broadcasters

get only local stations. These locals would come in better with the detector contact off.

Regarding the Roberts knock-out two-tube set, I must say I have had excellent success with it. The hardest stunt I have asked of it yet was to bring in Louisville on 400 meters through WJAX on 390. It did its best—angels could do no more. I heard Louisville right through WJAX which isn't bad since there is only ten meters difference between the two stations, and Louisville has a power of $\frac{1}{2}$ k.w., 400 miles away, while WJAX has 1 k.w. and is about four miles away from me.

I did several things which Roberts did not specify. I brought the taps on the A coil out to switch points on the panel, which helped selectivity and volume and then I put the whole coil on a lever, with a control knob on the panel so that the coupling with the primary S coil could be varied—which is an advantage. The T coil is on a lever at the end of a horizontal shaft which can be rotated. The coupling can be varied in a vertical plane (fanwise) which makes for compactness. With this set last night I heard (on the loud speaker) WFI, KFKX, WFAA, WGY, WHAS, WOR, WCAL, WBZ, WDAP, KDKA, WGN, WOC, and WBAP.

J. E. ROBERTS,
Cleveland, Ohio

Radio and Shorthand

Editor, RADIO BROADCAST,
Doubleday, Page & Co.,
Garden City, L. I.

DEAR SIR:

When I first became a radio fan, I merely listened-in as a pastime. Now I have found another use for my radio.

One can usually tune-in some lecture or talk on general topics of the day, and I have found that my

shorthand has been greatly improved since I started the practise of spending about a half hour each evening, copying down what I hear.

I used to think that I got enough practise during the day doing my regular work, but in taking dictation, I find usually I am more concerned in getting every word than in neatness of the result. And when I am copying what I hear over the radio, it does not matter if I miss a few words, and I can pay more attention to the size and shape of the shorthand characters, and so get splendid practise that I cannot get during working hours.

SALMER PETERSON,
Arlington, S. Dak.

Not So Fast, Announcers

Editor, RADIO BROADCAST
Doubleday, Page & Co.,
Garden City, L. I.

DEAR SIR:

The writer, a radio fan, in the name of all the radio fans in the Island of Cuba, respectfully addresses to you this letter in order through your magazine to call the attention of all the broadcasting stations in the United States to the fact that it is next to impossible to understand the name or initial of the transmitting station because the announcers in general speak extremely fast and this, added to the static, keeps us from knowing who is transmitting.

During the past few months, I have been experimenting in order to ascertain the distance I could reach with my receiving set and regularly every night hear Los Angeles, Fort Worth, Alabama, Davenport, Pittsburgh, and others. I received the concerts well, but was not able to identify the stations until the second or the third number, due to the extreme speed of the announcers when giving the initials.

Undoubtedly you are aware that there are in the neighborhood of 25,000 radio amateurs in Cuba and they are very much interested in hearing the States.

If you will be so kind as to write an article in your magazine with regard to the above, I can assure you the favor will be appreciated by all the radio fans in Cuba.

Yours very respectfully,
OSCAR H. STA. CRUZ
Habana, Cuba.

SIX MEN IN A DIRIGIBLE

BATTLING fog and wind, pushing bravely toward the North Pole. . . How the first wireless apparatus ever put aboard an airship dramatically saved six lives. —Told by Jack Irwin, the Marconi wireless operator aboard Walter Wellman's dirigible AMERICA on its fateful Atlantic voyage in October, 1910. The story will appear in an early number.

For the Fullest Measure

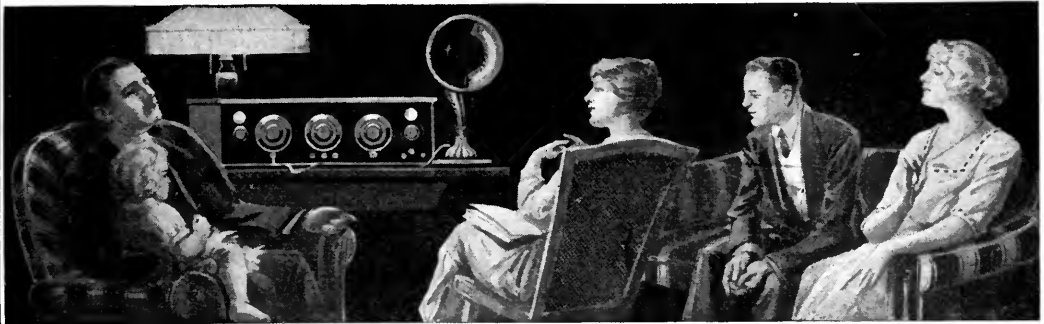

of Undistorted Volume

To obtain the fullest measure of undistorted volume, your receiver must deliver to the diaphragm of your loudspeaker or ear phones audio frequencies which will produce the maximum volume and purest qualities of tone.

This depends directly upon the efficiency of your audio amplifying transformers.

The GENERAL RADIO CO. type 231-A is distinctly a quality transformer—of high electrical and mechanical efficiency.

Features contributing to its superior performance are:

- Low loss steel** used in its core construction
- Layer Winding** properly insulated and impregnated
- Air gaps in core** to avoid distortion
- Unbreakable feet** with convenient mounting holes
- Heavy leads** with soldered connections
- High and flat amplification curve**

Which indicates that amplification is nearly uniform throughout its entire audio range, making it **best for all stages.**

Turns ratio 3.7 to 1

Impedance ratio 10 to 1

Instructive Folder on "Quality Amplification" sent free on request

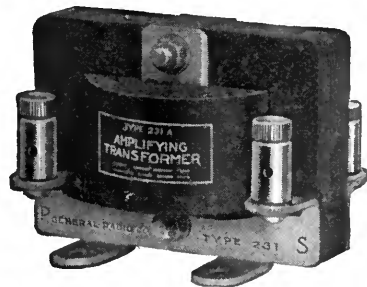

Type 231-A
AMPLIFYING TRANSFORMER
"Best For All Stages"
PRICE \$5.00

*Sold by Good Radio Dealers
EVERYWHERE*



"Products of Proven Merit"

GENERAL RADIO COMPANY
Manufacturers of
Radio and Electrical Laboratory Apparatus
Massachusetts Ave. and Windsor St.
CAMBRIDGE MASSACHUSETTS

GENERAL RADIO Co.



In writing to The Grid for constructional data, correspondents are requested to send a stamped self-addressed envelope with their letter of inquiry and also to furnish the editor with all possible information concerning the use to which the apparatus is to be put. This should include, when pertinent, type of tube, wavelength, voltage, current, sizes, the experience of the correspondent and a description of available material. This will greatly add to the facility with which our advice may be carried out, and to the general usefulness of this department.

QUERIES ANSWERED

- | | |
|--|------------------------------------|
| DESCRIBE THE CONSTRUCTION OF A LOOP FOR THE SUPER-HETERODYNE | <i>A. S., Farmington, Me.</i> |
| WHAT ARE THE DIMENSIONS, NUMBER OF TURNS, ETC. OF THE OSCILLATOR-COUPLER FOR THE HAYNES SUPER-HETERODYNE | <i>A. C. S., Hazen, Ark.</i> |
| HOW CAN I DECREASE THE RADIATION OF MY SINGLE CIRCUIT "BLOOPER?" | <i>O. M. W., Key West, Fla.</i> |
| WHAT IS THE PURPOSE OF THE GRID LEAK AND CONDENSER? WHAT IS ITS ACTION IN A RECEIVER | <i>J. C. B., Brooklyn, N. Y.</i> |
| IS A TUNED RADIO-FREQUENCY AMPLIFIER MORE TO BE DESIRED THAN THE UNTUNED TRANSFORMER-COUPLED TYPE? | <i>G. E. C., Seattle, Wash.</i> |
| HOW CAN I ELIMINATE INTERFERENCE FROM LOCAL HIGH-POWERED BROADCASTING STATIONS | <i>W. J. S., Chicago, Ill.</i> |
| WHAT KIND OF A RECEIVER SHALL I BUY? WOULD YOU ADVISE TRYING TO BUILD MY OWN? | <i>A. D. C., Philadelphia, Pa.</i> |

LOOPS

THE most desirable size of loop for broadcast reception is a compromise between the more efficient larger sizes and the convenience and mobility of a small frame. We recommend a square loop, three feet on a side, the various dimensions of which are indicated on the working drawing of Fig. 2.

The loop is of the solenoid type, i.e., wound in "box" form rather than as a spiral. There are nine turns of wire, separated one-half inch, wound in grooves, sawed in the end pieces. Any convenient wire may be used. Green double silk covered, No. 18 is perhaps the most easily manipulated, and when wound on a stained frame, the finished loop presents a very creditable appearance.

The frame is constructed of 1" by 1 1/2" lumber. The upright may be drilled at the lower support on which the wires are strung to pass the middle wire. The other wires of course pass on either side of the upright. The construction of the base is clearly shown, the holes through the top and into the bottom being one inch in diameter, and the lower eight inches of the upright rounded to fit with sufficient looseness to permit turning of the coils.

Fig. 1 shows the approximate wavelength range of this loop when shunted by the average .0005 mfd. plate condenser.

This loop is especially adapted for use with the Haynes super-heterodyne receiver, and multi-stage radio-frequency amplifiers. It may also be used with a proper receiver as a direction finder.

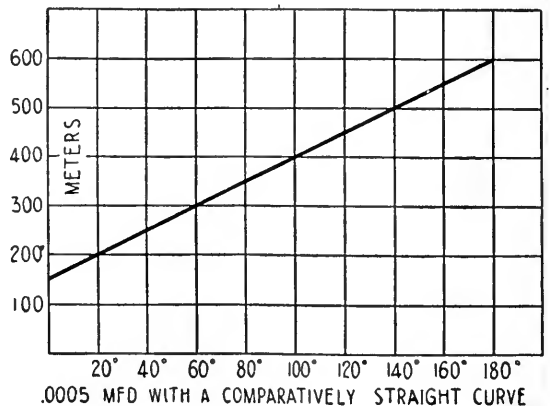

FIG. 1



FADA

*Announces a New Audio Frequency Transformer
and New Variable Condensers*

FADA
Audio Frequency
Transformer
No. 171-A, \$6.00

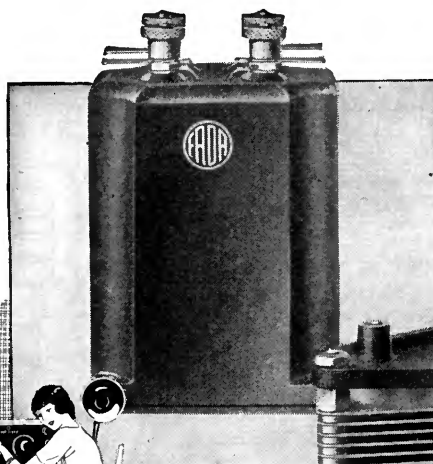

FADA
Variable Condensers
No. 142 (15
plates .0003 mf)
\$3.00
No. 144 (23
plates .0005 mf)
\$3.50

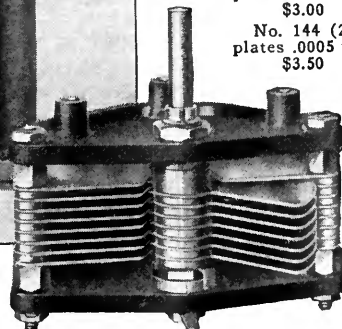

IN KEEPING with its established policy of producing only the finest of radio apparatus, F. A. D. Andrea, Inc., announces a new Audio Frequency Transformer suitable for all circuits, and particularly adapted to Neutrodyne receivers.

A high average amplification over all audio frequencies is the outstanding accomplishment of this new FADA transformer. Encased in bakelite with nicked binding posts, it looks twice its worth. Try FADA Audio Transformers in your receiver and know what uniform and distortionless amplification really means.

The name FADA on a condenser means just one thing—condenser satisfaction. The new FADA condenser is made in two capacities—15-plate, capacity .0003 micro-farads, and 23-plate, .0005 micro-farads; and each the exact capacity at which it is rated. Radio frequency losses are reduced to a minimum by special rotor wiping contact brushes. A true “low-loss” condenser with an efficiency exceeding that of condensers selling at much higher prices.

Dealers are now ready to supply FADA transformers and condensers.

F. A. D. ANDREA, INC., 1581 Jerome Avenue, New York



★ Tested and approved by RADIO BROADCAST ★

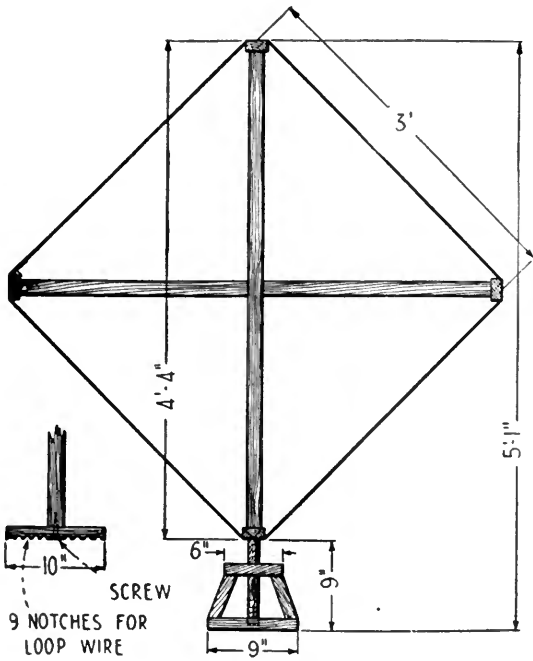

FIG. 2

AN OSCILLATOR COUPLER FOR THE HAYNES
SUPER-HETERODYNE

DIMENSIONS for a suitable coupler are as follows: The stator is of formica or bakelite tubing, $3\frac{5}{8}$ " in diameter and $2\frac{1}{2}$ " long. It has two coils wound on it, each of 18 turns of No. 22 D.C.C. wire. The coils are separated by a $\frac{1}{4}$ " space.

The rotor is of the same material and is 3" in diameter and $1\frac{1}{2}$ " long. One coil of 15 turns of the same wire is wound on it.

Mechanical details of the mounting support and rotor shaft have been omitted as these differ in various types of standard couplers. The stator coil is set at a 45° angle to

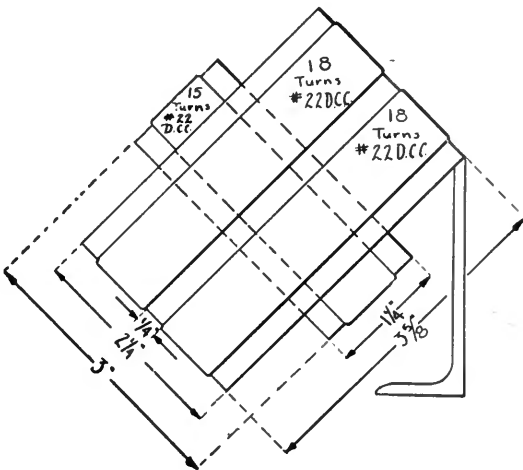

FIG. 3

the base. This reply gives only the dimensions of the coil forms and number of turns for each winding. See Fig. 3.

SINGLE CIRCUITS AND "BLOOPER"

AN EASY, quick method of changing over your single-circuit "blooper" into a double-circuit receiver with the chances for radiation materially reduced, is shown in Fig. 4. The dotted lines show how the circuit looked as a single-circuit radiator. Coils S and T are the stator and rotor respectively of a standard coupler. C₁ is changed from the series antenna connection to a shunt connection across the stator which then becomes the secondary. The primary consists of about ten turns of D.C.C. wire (sizes 24 to 18 will do) wound directly over the secondary. This serves as an untuned primary.

When the wave trap, shown elsewhere in these columns is used with this modified circuit, an additional absorption circuit is provided which also tends to diminish the radiation of the type of receiver to a negligible quantity.

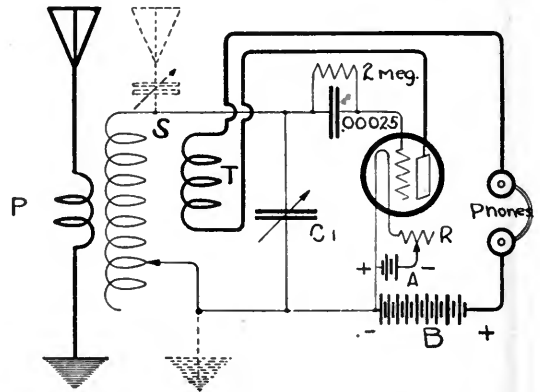

FIG. 4

THE GRID LEAK AND CONDENSER

THE grid leak and condenser supplies the grid of the tube with rapid surges of electron changes.

The theory of its action is as follows:

Suppose electrons surge from the tuner windings into one side of the grid condenser. The electrons which were on the grid side of this condenser will then rush out on to the grid of the tube, and cut down the plate current. But this will be so quick as to produce no effect in the telephones. On the back surge, however, something else will happen. The electrons will then rush out of the tuner side of the grid condenser to such an extent as to pull some electrons away from the grid of the tube, and thereby make it positive. This will mean that some of the free electrons in the tube will be drawn to the grid of the tube and out on to the wire connecting the grid to the condenser. On the next return surge of electrons on the tuner side of the condenser from the tuner, these extra electrons which came from the tube are no longer free, but are trapped between the condenser and the grid of the tube. They cannot get out of the grid back into the vacuum of the tube because the grid is not heated as the filament is. The result is that the grid is more negative than it was before because of the excess of the electrons it now has. The plate current in the tube will therefore go to a lower value than it did before. This trapping of electrons will continue on each positive swing of the grid so that the grid will soon reach an average negative value below where it started, by

hours spent to solder
connections carefully
... wires shortened
... circuits altered ...

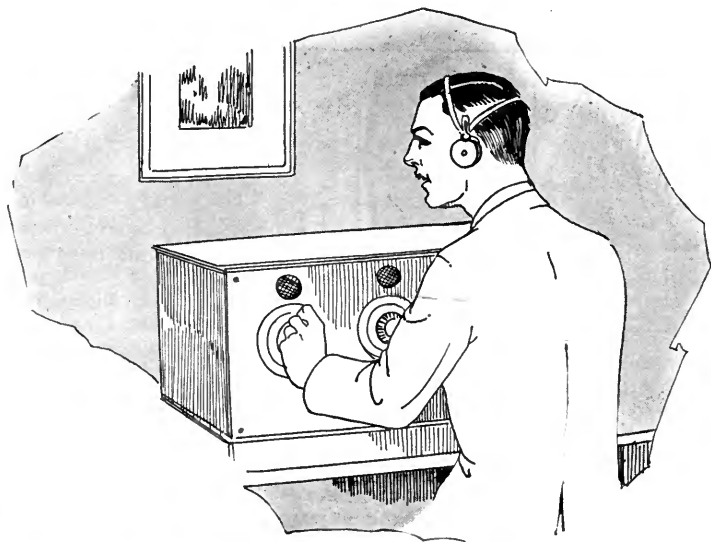

and still energy leaks away

WHAT a tiny fraction of broadcast energy actually gets to your set! How vital it is to prevent a particle of that energy from leaking away!

Yet in the most carefully constructed set, there are scores of places where stations you particularly want can literally leak away!

For every small part must convey current before energy gets to your phones or speaker. It's mighty important to you to know that every one of them is doing its full duty to prevent energy leaks.

MAR-CO small parts are made with precision, by the makers of scientific instruments—designed to stop leaks and conserve precious energy!

The compactness, the sure contacts hundreds of thousands have found in MAR-CO instruments, would be worth high prices. Actually, they save you money when you buy . . . just as they save stations that might otherwise leak away—when you use them!

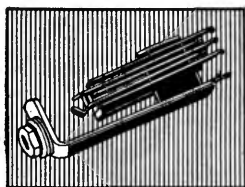

Eliminate short circuits with MAR-CO SHUR-GRIP jacks—Formica insulation, sterling silver contacts, hooked terminals for quick, leak-proof connections—60 cents to \$1.00 and well worth it.

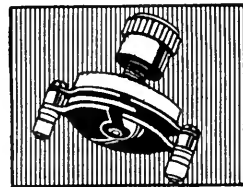

The compact, leak-proof construction, and the amazingly smooth, easy operation, of MAR-CO neutralizing condensers works wonders in R.F. circuits. Perfect neutralizing of tube capacity for \$1.25.



MAR-CO

PLUGS • JACKS • RHEOSTATS • SOCKETS



SWITCHES • NEUTRALIZING CONDENSERS

★ Tested and approved by RADIO BROADCAST ★

Digitized by Microsoft®

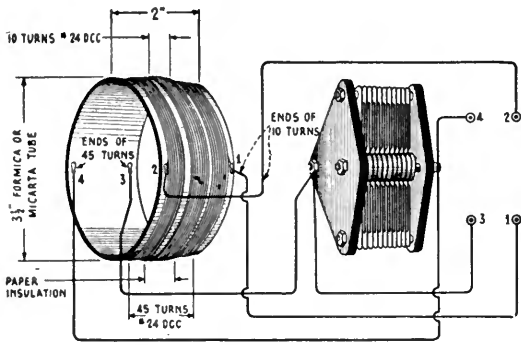

FIG. 5

The four binding posts allow use of this circuit in various ways. For general use, post 1 goes to the antenna, and post 2 to the antenna post on the receiver

the number of electrons which are trapped. This means that the average plate current will be correspondingly decreased, the telephones will be affected by this decrease in plate current. It is therefore necessary to bring the grid back to its original condition if the oscillations in the antenna have stopped.

The grid leak which is shunted across the grid condenser permits the trapped electrons to "leak" out into the set. For further details see the interesting and helpful book, *The Radio Pathfinder*, by R. H. Ranger.

TUNED R. F. AMPLIFIERS VERSUS UNTUNED R. F. AMPLIFIERS

THERE is something to be said in favor of both of the methods of radio frequency amplification mentioned. The transformer system needs no adjusting, per stage. Excepting for the ordinary tuning of the input coupler controlling the received wave, there is no further adjustment of the tuner.

In the tuned R. F. amplifier each stage must be tuned separately to resonance with the incoming wave. This operation is complicated and not always easy. But, when each stage has been properly adjusted, the reception is exceptionally good. One drawback of a set having tuned radio-frequency amplification is that the self-oscillations of the tubes make it a difficult set to control. This has been partly overcome by incorporating in the set, neutralizing capacities, resulting in a circuit similar to the standard neutrodyne set. The disadvantage in using untuned transformers is that they will not work with the same efficiency on all wavelengths. The wavelength at which best results are obtained is called the "peak."

INTERFERENCE AND THE WAVE-TRAP

IN A recent article by Mr. A. J. Haynes (November, 1923) this question of eliminating local interference was answered in detail. However, Fig. 5 shows the circuit diagram for a wave trap which will accomplish this elimination.

The inside winding is a coil consisting of 45 turns of No. 24 D.C.C. wire wound on a 3 1/2" diameter tube, 2" long. The outside coil is wound directly over the first coil, being separated by a piece of linen or cambric cloth. It consists of 10 turns of No. 24 D.C.C. wire. Figs. 5 and 6 show the circuit, and method of coupling to a receiver.

CHOOSING A RECEIVER

THERE are several limitations that must be taken into consideration when choosing a receiver. Those of first importance are: amount to be spent; location, i.e., use of loop or outdoor aerial; purpose of its use, i.e., general broadcast reception for entertainment or experimentation.

A one-tube reflex set is comparatively cheap, efficient in operation, and has the advantage of working a loud speaker for local reception.

A three-tube reflex will permit the reception of distant stations on a loud speaker, is selective in tuning and is generally conceded to be a standard type of home receiver. A three-tube regenerative set is also excellent although the novice experiences some difficulty at first in effectively operating it.

A five-tube neutrodyne is an exceptional distance-getter, but on account of the multiplicity of controls is rather unwieldy to handle for one who knows nothing at all about radio.

The super-heterodyne is the "high-powered" par excellence receiver of radio. Simple in operation and effective for long distance reception, this set can surely be called the highest type of radio receiver yet developed. Most super-heterodynes are designed for loop reception.

The sets described will fit all sizes of pocketbooks and all have been described in past issues of RADIO BROADCAST.

There is an advantage to building your own since the experience gained enables one to understand the workings of the set. If one is especially handy with tools, the building of a set is heartily recommended.

In the May issue of the Grid a list of receivers that do not radiate, was given. We advise prospective purchasers of radio receivers to consult this list.

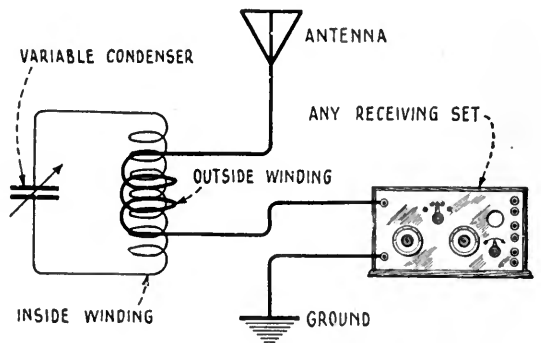

FIG. 6

HOW to build a broadcasting station using two five-watt tubes, is the subject of an unusually complete how-to-make-it article which will appear in this magazine for July. It is written by Ashley C. Dixon of Stevensville, Montana, owner of station KFJR and author of "What Radio Means at a Rocky Mountain Ranch" in RADIO BROADCAST for January.

“GOLDEN-LEUTZ”

SUPER-PLIODYNE 9



THE PERFECT BROADCAST RECEIVER

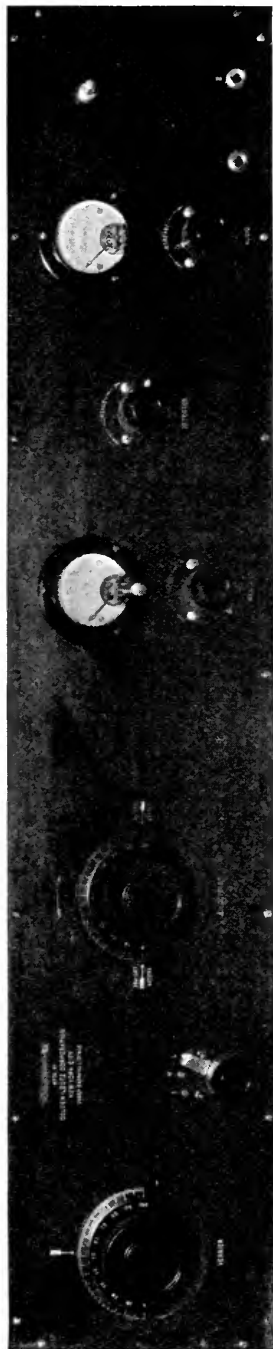

SIZE 40" x 8" x 8"

WEIGHT 65 LBS.

MANUFACTURED UNDER FARRAND LICENSE

A New Broadcast Receiver having 5 stages of Tuned Neutralized Radio Frequency Amplification, Detector and 3 stages of Audio Frequency Amplification

Built for People Who Want the Best

Complete Illustrated Catalogue and Instruction Book Mailed Upon Receipt of 25c

GOLDEN-LEUTZ INCORPORATED, 476 Broadway, New York City

★ Tested and approved by RADIO BROADCAST ★

New Equipment

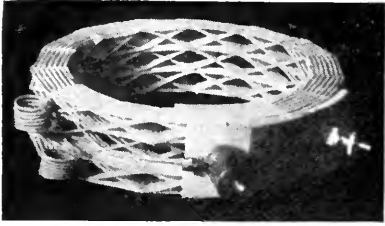

SICKLES DIAMOND WEAVE COIL

A coil of substantial construction which largely eliminates bulky insulating materials. It is readily mounted and does not require a great amount of space. The distributed capacity is material reduced and at final analysis it is quite efficient electrically. These inductances have been made to supply the demand for the coils T₁ and T₂ in the RADIO BROADCAST Knock-out sets. Made by the F. W. Sickles Company, Springfield, Mass.

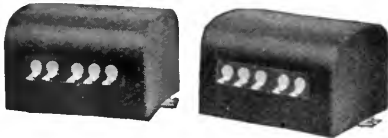

COMO TRANSFORMERS

A sturdy pair of push-pull transformers, one input and one output. Using these, the radio fan can build a very satisfactory push-pull amplifier. Made by The Como Apparatus Company, 446 Tremont St., Boston, Mass. Price \$12.50 per pair

ACCURATUNE MICROMETER DIAL

This is a control which not only adds to the appearance of your set but also makes for fine tuning. The micrometer adjustment is very effective on the most critical receivers. Made by The Mydar Radio Company, Newark, N. J. Price \$3.50



HAMMARLUND MODEL "B" CONDENSER

A well built piece of apparatus which reduces electrical losses to a minimum. The plates of hard brass are pressed into slotted brass posts and soldered, thus eliminating the possibility of material dielectric losses. Body capacity effect is prevented by grounding the aluminum end plates making it unnecessary to use shielding. The vernier control used makes extremely fine tuning possible as well as accurate logging. Made by Hammarlund Mfg. Co., Inc., 144-146 West 18th St., New York City

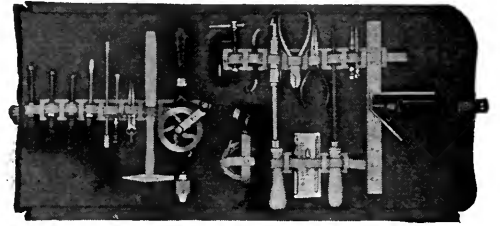
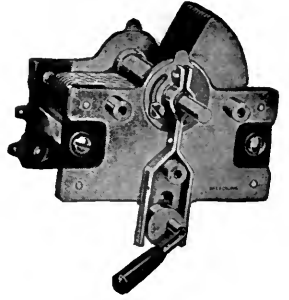

"GNOME BRAND" RADIO TOOL KIT NO. 1

A kit which is worthy the attention of radio fans generally. It contains all the tools which would ordinarily be needed by the home builder of receiving sets and the quality is first class. Hammacher, Schlemmer & Co., Inc., New York City. Price \$20.00

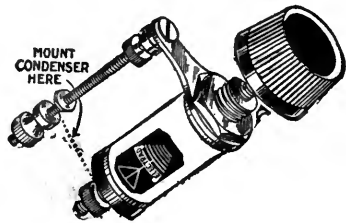

ELECTRAD VARIOHM

A variable resistance rated by the manufacturers between five thousand and one hundred thousand ohms. Designed for panel mounting with adjusting knob. It may be used as the coupling resistance in resistance-coupled amplifiers. Made by The Electrad Corporation, New York City

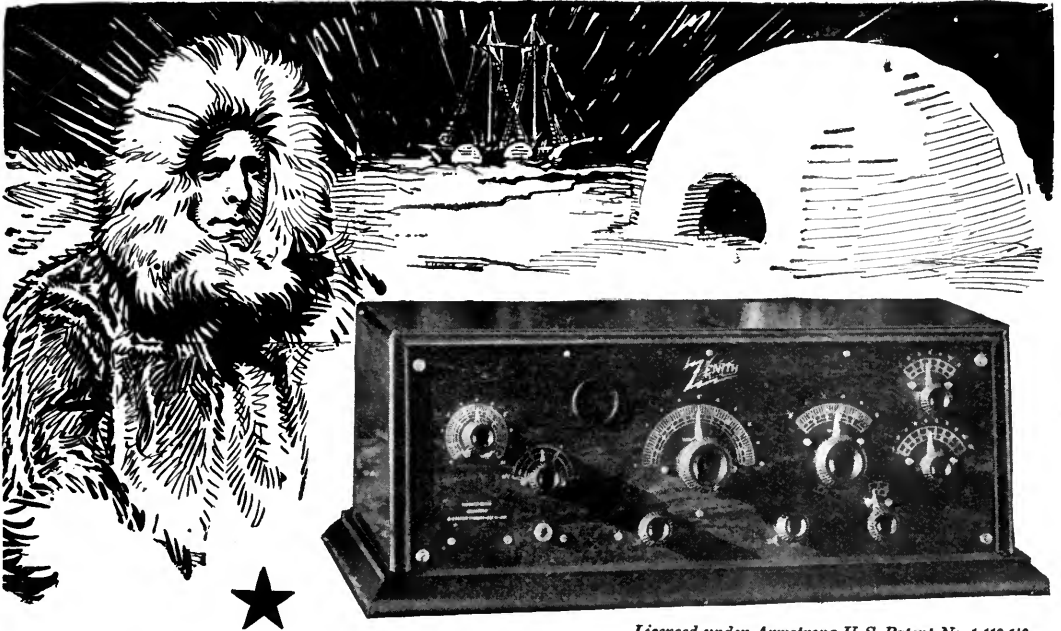

Licensed under Armstrong U. S. Patent No. 1,115,149

MacMillan Listens to Honolulu and New Zealand "Tunes In" California

From a little ice-bound schooner—eleven degrees from the North Pole—comes this message:

"Am very thankful that Arctic Exploring Ship Bowdoin is equipped with complete Zenith radio apparatus. Here at top of world, in darkness of great Arctic night, we have already listened to stations practically all over the United States, from Europe, and even from far away Honolulu. Zenith has united the ends of the earth.—MacMillan."

Again, from far-off New Zealand comes a report of radio reception even more startling:

"It may interest you to know that the writer last evening landed KGO, Oakland, California, between 6:45 and 7:30 P.M. Heard his call four or five times distinctly, and jazz music. As San Francisco is 6,300 miles from New Plymouth, and only one tube was used, we think this is a very fair performance."

—(signed) H. Charles Collier.

The sets used by Captain MacMillan and Mr. Collier are earlier models—since improved by the addition of a *third stage of audio frequency*. These new models represent an achievement not duplicated in any other set on the market. Write today for full particulars and name of nearest dealer.

Zenith Radio Corporation
McCORMICK BUILDING, CHICAGO, ILLINOIS



Model 3R The new Zenith 3R "Long-Distance" Receiver-Amplifier combines a specially designed distortionless three-stage amplifier with the new and different Zenith three-circuit regenerative tuner.

Fine vernier adjustments—in connection with the unique Zenith aperiodic or non-resonant "selector" primary circuit—make possible extreme selectivity.

2,000 to 3,000 Miles With Any Loud-Speaker

With the new Zenith 3R satisfactory reception over distances of 2,000 to 3,000 miles, and over, is often accomplished in full volume, using *any ordinary loud-speaker*. The Model 3R is compact, graceful in line, and built in a highly finished mahogany cabinet **\$160**

Model 4R The new Zenith 4R "Long-Distance" Receiver-Amplifier comprises a complete three-circuit regenerative receiver of the feed-back type. It employs the new Zenith regenerative circuit in combination with an *audion detector* and *three-stage* audio-frequency amplifier, all in one cabinet.

The Zenith 4R may be connected directly to any loud-speaker *without* the use of other amplification for full phonograph volume, and reception may be satisfactorily accomplished over distances of more than 2,000 miles **\$85**

ZENITH RADIO CORPORATION,
Dept. 1-G 328 South Michigan Avenue, Chicago, Ill.

Gentlemen:
Please send me illustrated literature on Zenith Radio.

Name

Address

★ Tested and approved by RADIO BROADCAST ★

New Equipment—Continued

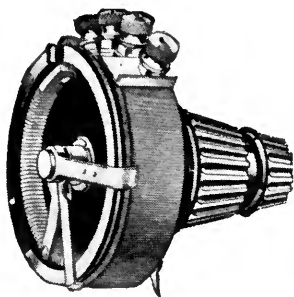

RADIO TUBE CONTROL UNIT

A compact device combining rheostat, vernier and potentiometer mounted as one unit, with two knob control. It is made of moulded bakelite. One knob controls the rheostat and the vernier, the other knob controls the potentiometer lever. Made by Herbert H. Frost, Inc., Chicago, Illinois. Price \$1.75

PONS RADIO AND BATTERY CLIP

An inexpensive clip with a spring in the center and jaws on either end which makes this device valuable wherever there are radio sundries. The clip may join two batteries, or place telephone leads in series—among other uses. Made by Eugene Pons, 838 Lincoln Ave., Schenectady, N. Y.

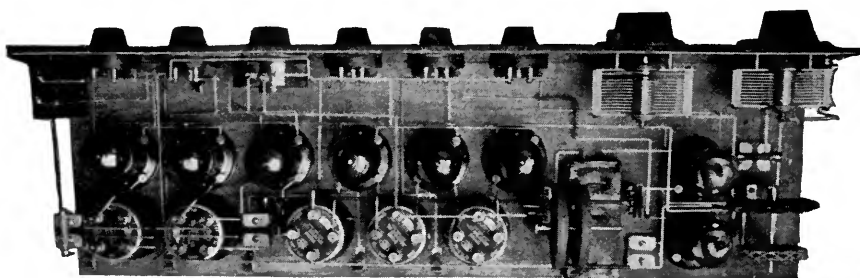

A SUPER-HETERODYNE

The photo shows what has been done with parts manufactured by the Radio Receptor Company, New York City

Supplemental List of Broadcasting Stations in the United States

LICENSED FROM MARCH 21 TO APRIL 18 INCLUSIVE

CALL LETTERS	LOCATION	(KILO-CYCLES)	WAVE LENGTH	POWER (WATTS)
KFFP	Moberly, Mo.	1130	266	50
KFPH	Salt Lake City, Utah	1240	242	50
KFPL	Dublin, Texas	1240	242	20
KFPM	Greenville, Texas	1240	242	10
KFPN	Jefferson City, Mo.	1240	242	10
KFPP	Olympia, Washington	1270	236	20
KFPQ	Denison, Texas	1300	231	10
KFPR	Los Angeles, Calif.	1300	231	500
KFPS	Casper, Wyoming	1240	242	10
KFPV	San Francisco, Calif.	1270	236	50
KFPW	Cartersville, Mo.	1120	268	20
WABB	Harrisburg, Pa.	1130	266	10
WCBO	Memphis, Tenn.	1200	250	20
WCBO	Nashville, Tenn.	1270	236	100
WCBR	Providence, R. I.	1220	246	5
WCBT	Worcester, Mass.	1260	238	250
WCBU	Arnold, Pa.	1180	254	50
WCBV	Tullahoma, Tenn.	1190	252	10
WDBF	Youngstown, Ohio	1220	246	50
WEAR	Baltimore, Md.	1150	261	50
WHO	Des Moines, Iowa	570	526	500
WIAY	Washington, D. C.	1100	273	100
WLS	Chicago, Ill.	870	345	500

TOTALS

Number of U. S. broadcasting stations	598
Number of Canadian broadcasting stations	44
Number of Cuban broadcasting stations	34

Atlas

TRADE MARK

RADIO-REPRODUCTION

LOUD SPEAKER

"The Musician of the Air"

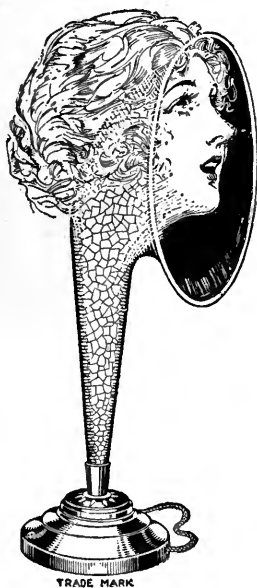

TRADE MARK

Complete \$25



Atlas Unit with
phonograph coupling \$13.50

Presidential Conventions!

*The Republican Convention,
Cleveland, June 10.*

*The Democratic Convention,
New York, June 24.*

A Message to the Public!

THE very next best thing to being actually present at these two events, of national and international importance, is to hear their ATLAS RE-PRODUCTION. Bring these momentous proceedings and orations right into your home in all their original naturalness for the entertainment and instruction of your family and friends. Get *all* of these speeches, every word clearly inflected, in the full, undistorted tones of the speaker. Just as realistic as though you were actually there. Buy your ATLAS NOW!

Booklet "A" upon request

Multiple Electric Products Co. Inc.

Makers of Mono—TIME—LAG FUSES—Multiple

2 ORANGE ST.

NEWARK, N. J.

District Offices in

Boston, Mass. Philadelphia, Pa. Baltimore, Md. Pittsburgh, Pa. Detroit, Mich.
Chicago, Ill. St. Louis, Mo. Denver, Colo. San Francisco, Cal.



Sole Canadian Distributors:

Marconi Wireless Telegraph Co. of Canada Ltd., Montreal, Canada.

★ Tested and approved by RADIO BROADCAST ★

Among Our Authors

THE artist who is responsible for our cover this month is Remington Schuyler. In Wyoming, he is known to the Indians as Ta-tan-ka-luta, which, being translated means Red Buffalo. Mr. Schuyler is regarded as a highly authoritative painter of Indians, even by the Indians themselves. At his home in New Rochelle, N. Y., Mr. Schuyler has done much for the Boy Scouts, who, naturally enough, are not unenthusiastic about close associations with a real Westerner.

JULIAN KAY is a radio man who was toying with spark coils and unwilling crystal detectors back in the days when an antenna atop a house was a matter for uncomfortable neighborly astonishment and disapproving shaking of heads. He and the editor were discussing the present Greek confusion of radio names one day, whereupon Mr. Kay waxed so enthusiastic that his present excellent article is the result. There are several others to follow.

ZEH BOUCK is a busy contributor to our magazine. Of late, he has associated himself with the William P. Mullaly Company, advertising agents, and has organized a radio department for them. When we talked with him recently, he was momentarily three centuries away from radio, deep in the absorbing pages of Burton's *Anatomy of Melancholy*.



CARL DREHER

WITH designing malice, we think, Carl Dreher took this snapshot himself atop Æolian Hall, which houses the apparatus of WJZ and WJY, with the purpose of showing that he is quite above radio, but we know better, though he writes: "In my spare time I am a practitioner of the art of writing fiction. Engineers all say I am a good writer, and writers praise me as an engineer. As a result of this striking unanimity of opinion, I don't know *what* the devil I am." Mr. Dreher does not always put himself on a pedestal.

THERE are few men who have been radio operators who have had a jollier time at it than George F. Worts whose thrilling, straightforward tale of one eventful night on the miscalled Pacific appears in this number. Mr. Worts has been in most of the ports on both sides of the Pacific in most of the many types of ships one finds there. Now he is living in the center of that interesting colony of artists and writers at Westport, Connecticut, where he writes the magazine stories which many of us enjoy.

H F. MULLETT is on the staff of the *Edmonton Journal* and confides that he is English by birth, but really can't help that. "I came to Canada on the night boat twelve years ago," he writes, "successfully evading the line-up of creditors at the docks. For five years I worked for the Alberta government, but reformed and went into journalism."



H. F. MULLETT



R. E. SHLUKBIER

R E. SHLUKBIER is a native of Michigan—Saginaw, to be exact. During the war, he went through the Harvard Radio School, later became a Naval operator with the fleet, and since his demobilization has been a commercial operator in the merchant marine.

"A Word from the Enemy" is the result of opinions thought out during quiet tricks at the key.

BOWDEN WASHINGTON sends his article "How to Build a Teledyne Radio Receiver," from Minneapolis where he is now located as chief engineer of The Cutting & Washington Radio Corporation. In 1916 he joined with Dr. Fulton Cutting, forming the firm with which he is now connected. "In 1917," Mr. Washington writes, "I developed the first new marine transmitter since 1907, of which more than \$750,000 worth were made and sold."

Watch the radio columns of your newspaper for the big convention broadcast schedules.

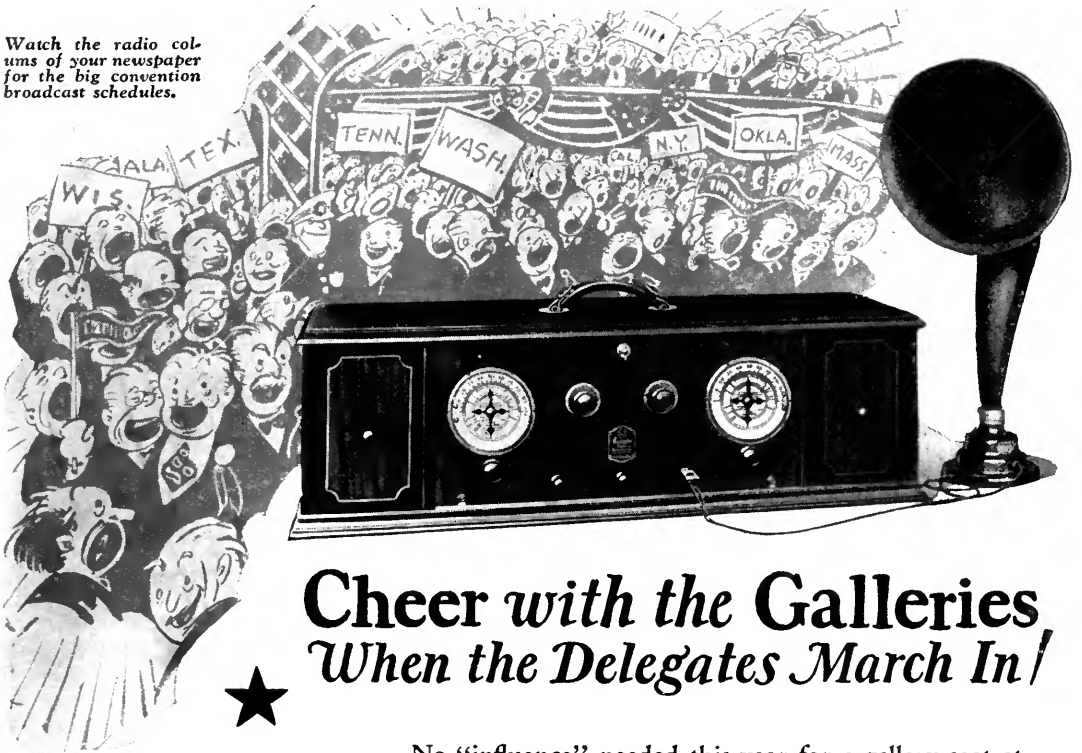

**Cheer with the Galleries
When the Delegates March In!**

Radiola Super-Heterodyne

It needs NO ANTENNA—no ground—no connections of any kind. Has a handle to lift it by. Tunes in with just two knobs that you turn to marked spots on the dials. Tunes out powerful near stations to get the far ones. A wonderful new achievement in the perfection of its tone—its sensitivity—and its supreme selectivity!

Complete with six Radiotrons UV-199 and Radiola Loud-speaker; everything except batteries . . . \$286

External, rotating loop, easily assembled, larger than self contained loop in Radiola Super-Heterodyne, for extreme reception range. Loop A G 814 \$12.00

There are many Radiolas at many prices. Send for the free booklet that describes them all.

RADIO CORPORATION OF AMERICA
Dept. 36 (Address office nearest you.)
Gentlemen: Please send me your free Radio Booklet.

Name _____

Address _____

No "influence" needed this year for a gallery seat at the big political conventions! Get it all, with a Radiola Super-Heterodyne.

When the delegates march in—their banners streaming; when the bands play and the galleries cheer—be there with the "Super-Het." Hear the pros and cons as they fight their way to a "platform" for you. Hear the speeches for the "favorite sons." The sudden stillness when the voice of a great speaker rings out. The stamp and whistle and shrill of competitive cheering. Hear the actual nomination of a president.

It used to be all for the delegates' wives and the "big" folks of politics. Now it's for everybody. Listen in. Get it all! With the newest Radiola.

Radio Corporation of America

233 Broadway New York Sales Offices
10 So. LaSalle Street Chicago, Ill. 433 California Street San Francisco, Cal.

Radiola

REG. U.S. PAT. OFF.

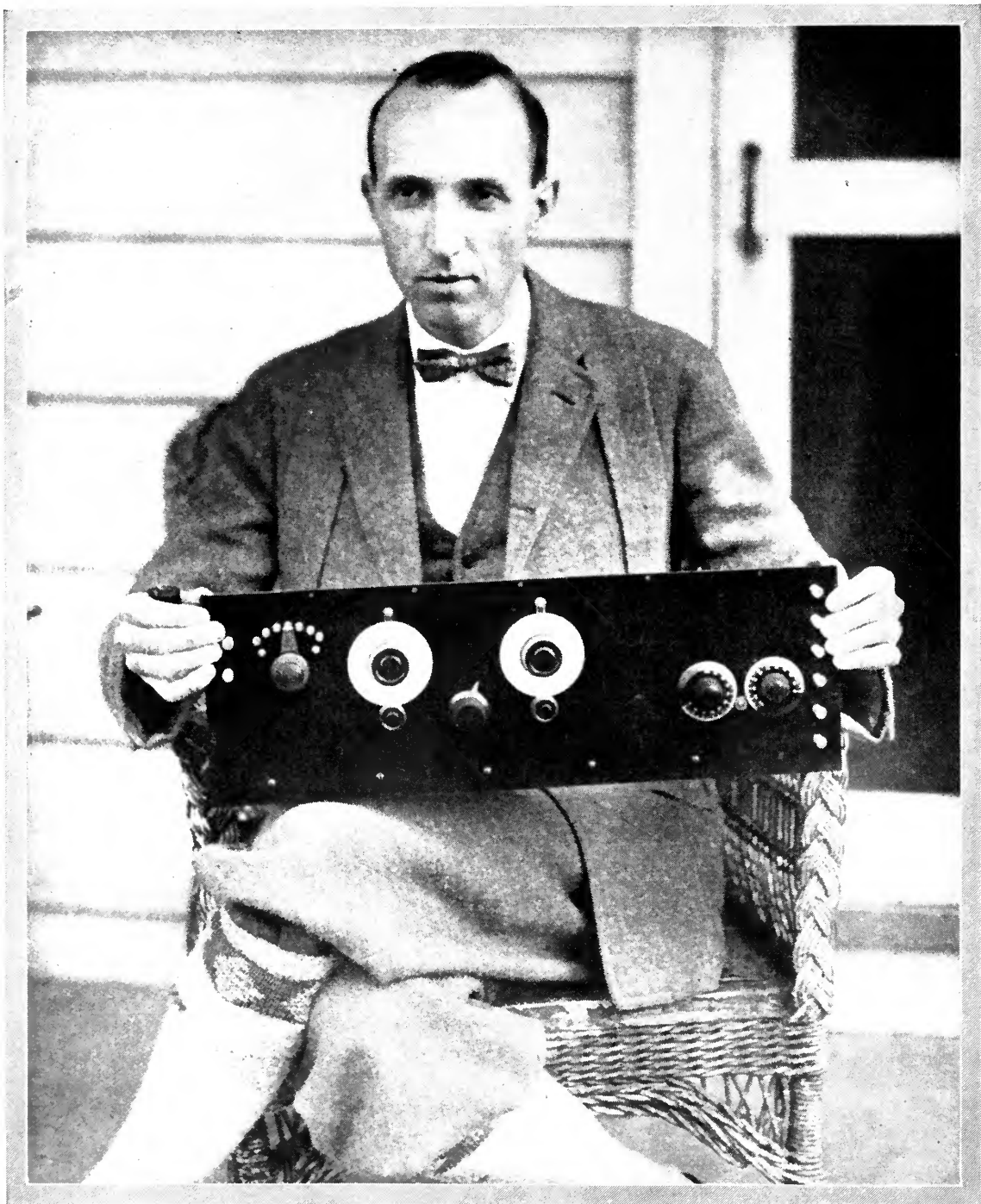

WALTER VAN BRAAM ROBERTS

One of the most highly regarded of the present radio technicians. He is designer of the Roberts Knock-Out Two-Tube set (RADIO BROADCAST for April and May), and author of "A Practical Super-Heterodyne using 199's" (August, 1923), and the technical serial "What Makes the Wheels Go 'Round." He is a graduate of Princeton University and is now doing research work there at the Palmer Physical Laboratories